



Out of the  
Department of Medicine IV– Grosshadern  
University Hospital of Munich University  
**Vietnamese vegetarian diet: does it affect the prevalence of metabolic syndrome?**

Doctoral Thesis  
for the awarding of a Doctor of Philosophy (Ph.D.)  
at the Medical Faculty of  
Ludwig-Maximilians - Universität, Munich

submitted by  
Nguyen Thi Anh Phuong  
born in  
Hue, Vietnam  
submitted on  
April 30, 2017

**Supervisors LMU:** Title, first name, last name  
Habilitation Supervisor **Prof. Dr. Klaus G. Parhofer**  
Direct Supervisor **Dr. Elisa Waldmann**

**Supervisor External:**  
Local Supervisor Prof. Dr. Cao Ngoc Thanh

**Reviewing Experts:**  
1<sup>st</sup> Reviewer **Prof. Dr. Klaus G. Parhofer**  
2<sup>nd</sup> Reviewer **Dr. Elisa Waldmann**

**Dean:** **Prof. Dr. med. dent. Reinhard Hicel**

**Date of Oral Defense:** 27/11/2017

## ABSTRACT

**BACKGROUND:** In Western countries vegetarians have less non-communicable diseases including metabolic syndrome than non-vegetarians. It is unclear whether the prevalence of metabolic syndrome also differs between vegetarians and non-vegetarians in Asian countries such as Vietnam. **SUBJECTS/METHODS:** We performed a descriptive, cross-sectional study on 183 monks and nuns who were  $\geq 30$  years of age and practicing a strict vegetarian diet for at least 5 years (84% females,  $58.8 \pm 16.0$  years; 16% males,  $56.5 \pm 15.4$  years) and 181 non-vegetarians selected from the same neighborhood in central Vietnam (71% females,  $51.1 \pm 14.5$  years; 29% males,  $57.5 \pm 13.8$  years). Metabolic syndrome was determined according to the 2009 Consensus Statement using specific thresholds for waist circumference for Asians. Direct age adjustment of the data was done for the Vietnamese population aged  $\geq 30$  years. **RESULTS:** Waist circumference, hip circumference and blood pressure in vegetarian males was significantly lower than in non-vegetarian males ( $p < 0.05$ ), while there was no significant difference in females. Total cholesterol, LDL-cholesterol and HDL-Cholesterol was significantly lower in vegetarians than in non-vegetarians while triglycerides were significantly higher (all  $p < 0.01$ ). The age-adjusted prevalence of metabolic syndrome in the total population was 19%. The prevalence was slightly lower in vegetarians (15.9%) than in the non-vegetarians (19.9%) without reaching statistical significance. **CONCLUSION:** In Vietnam the prevalence of metabolic syndrome is not significantly different between vegetarians and non-vegetarians, but different metabolic syndrome factors characterize vegetarians and non-vegetarians. Vegetarians have higher triglycerides and lower HDL-cholesterol, while non-vegetarians have higher blood pressure and higher LDL-cholesterol.

**Key words:** *metabolic syndrome, strict vegetarian, diet, Monks, Nuns, Vietnam*

## TABLE OF CONTENT

<b>1. INTRODUCTION</b> .....	1
1.1. Human energy needs .....	1
1.2. Some biological indicators assessing nutritional status. ....	5
1.3. Physiological and biochemical indicators related to cardiovascular function .....	6
1.4. Metabolic syndrome .....	8
1.5. Vegetarian diet .....	20
<b>2. RATIONALE AND OBJECTIVES</b> .....	27
<b>3. METHODS</b> .....	28
3.1. Study area: .....	28
3.2. Study population.....	28
3.3. Sampling. ....	29
3.4. Data collection.....	29
3.5. Variables .....	29
3.6. Instruments.....	33
3.7. Statistical analysis .....	37
3.8. Time of study.....	37
3.9. Ethical considerations .....	37
<b>4. RESULTS</b> .....	38
4.1. Demographic characteristics .....	38
4.2. Some biomedical indices of study and control group .....	41
4.3. Impact of vegetarian diet to metabolic syndrome .....	51
4.4. Vegetarian diet describing .....	55
<b>5. DISCUSSION</b> .....	<b>58</b>
5.1. Demographic Characteristics .....	58
5.2. Some biomedical indices of study and control group .....	60
5.3. Impact of vegetarian diet to metabolic syndrome .....	62
5.4. Vegetarian diet describing .....	64
5.5. Limitations of the research .....	66
<b>CONCLUSION</b> .....	68
<b>SUGGESTION</b> .....	69
<b>REFERENCES</b>	
<b>ANNEX</b>	

## LIST OF FIGURES

<b>Diagram 1.1:</b> Etiology of metabolic syndrome .....	18
--	----

## LIST OF TABLES

<b>Table 1.1.</b> Adult energy needs .....	2
<b>Table 1.2.</b> Basal metabolic rate via weight calculator .....	3
<b>Table 1.3.</b> The coefficient of the adult energy needs from the basal metabolism .....	3
<b>Table 1.4.</b> The adult need of minerals and vitamins .....	5
<b>Table 1.5.</b> Guidance parameters monitoring the status of blood lipids .....	7
<b>Table 1.6.</b> The WHO definition of Metabolic Syndrome .....	10
<b>Table 1.7.</b> EGIR definition of the Metabolic Syndrome .....	11
<b>Table 1.8.</b> NCEP- ATP III definition of Metabolic Syndrome .....	11
<b>Table 1.9.</b> AACE definition (American College of Endocrinology) of Metabolic Syndrome .....	12
<b>Table 1.10.</b> The IDF definition of Metabolic Syndrome .....	12
<b>Table 1.11.</b> Criteria for Clinical Diagnosis of the Metabolic Syndrome Measure .....	13
<b>Table 1.12.</b> Current recommended Waist Circumference Thresholds for Abdominal obesity by Organization .....	13
<b>Table 1.13.</b> Abnormalities associated with insulin resistance/ hyperinsulinemia .....	19
<b>Table 3.1.</b> Standard Height of Vietnamese people .....	34
<b>Table 3.2.</b> Standard Weight of Vietnamese people .....	34
<b>Table 3.3.</b> Standard BMI of Vietnamese people .....	35
<b>Table 4.1.</b> Gender Distribution .....	38
<b>Table 4.2.</b> Age group distribution .....	38
<b>Table 4.3.</b> Occupational Distribution .....	39
<b>Table 4.4.</b> Distribution of educational background .....	39
<b>Table 4.5.</b> Distribution of lifestyle .....	40
<b>Table 4.6.</b> Distribution of Health Insurance coverage .....	40
<b>Table 4.7.</b> Distribution of Marriage status .....	41
<b>Table 4.8.</b> Height distribution .....	41
<b>Table 4.9.</b> Height distribution by age .....	42
<b>Table 4.10.</b> Weight distribution .....	42
<b>Table 4.11.</b> Weight distribution by age .....	43
<b>Table 4.12.</b> Distribution of Body Mass Index .....	43
<b>Table 4.13.</b> BMI distribution by age .....	44
<b>Table 4.14.</b> BMI classification .....	44
<b>Table 4.15.</b> Distribution of Blood Pressure .....	45

<b>Table 4.16.</b> Distribution of blood pressure by JNC VII classification.....	46
<b>Table 4.17.</b> Distribution of Waist Circumference.....	46
<b>Table 4.18.</b> Distribution of Hip Circumference .....	47
<b>Table 4.19.</b> Distribution of Waist- Hip Ratio .....	47
<b>Table 4.20.</b> Distribution of fasting glucose .....	48
<b>Table 4.21.</b> Classification fasting glucose by ADA 2013.....	48
<b>Table 4.22.</b> Distribution of lipid profile .....	49
<b>Table 4.23.</b> Distribution of lipid disorders .....	49
<b>Table 4.24.</b> Distribution of prevalence of metabolic syndrome and its criteria .....	51
<b>Table 4.25.</b> The association of risk factors and metabolic syndrome .....	53
<b>Table 4.26.</b> Distribution of food habits and practice .....	55
<b>Table 4.27.</b> Distribution of food composition related to energy .....	56
<b>Table 4.28.</b> Distribution of food composition related to mineral and vitamins.....	57

## **ABBREVIATIONS**

AACE	: American College of Clinical Endocrinology
AHA	: American Heart Association
BMI	: Body Mass Index
DALYS	: Disability Adjusted Life Years
DBP	: Diastolic Blood Pressure
DDT	: Dichloro diphenyl trichloroethane
EGIR	: European Group for study of Insulin Resistance
FAO	: Food and Agriculture Organization
HDL-Cholesterol	: High Density Lipoprotein Cholesterol
IAS	: International Atherosclerosis Society
IASO	: International Association for the Study of Obesity
IDF	: International Diabetes Federation
IFG	: Impaired Fasting Glucose
IGF	: Impaired Glucose Tolerance
LDL-Cholesterol	: Low Density Lipoprotein Cholesterol
MS	: Metabolic Syndrome
NCEP-ATP	: National Cholesterol Education Program- Adult Treatment Panel
NHLBI	: National Heart, Lung and Blood Institute
SBP	: Systolic Blood Pressure
TG	: Triglyceride
WC	: Waist Circumference
HC	: Hip Circumference
VN	: Vietnam



WHF : World Heart Federation

WHO : World Health Organization

WHR : Waist-Hip Ratio

## **1. INTRODUCTION**

Nowadays, the importance of diet and nutrition in human health is well established. Epidemiological, observational and clinical studies have contributed to our understanding of how and to what extent dietary factors may induce or prevent diseases. Among many different kinds of diets, the vegetarian diet has quickly found supporters in Western countries when it was shown that such a diet is an effective way to prevent diseases (eg. cardiovascular and metabolic diseases and even cancer) as well as to promote health (Anderson et al., 1999; Barasi and Robinson, 1999; Barr et al., 1994; Duncan and Bergman, 1999; Rao, 1999; Mezzano et al., 1999; Nicholson et al., 1999). In many Asian countries, vegetarianism originated from Buddhist principles with some variability in the diet composition. For many reasons, vegetarian diets have become a global trend. On the other hand, some studies indicate that vegetarianism may result in a deficiency of some minerals and nutrients (Alexander et al., 1994; Refsum, 2001). Therefore, vegetarianism is still a controversial issue and needs to be studied systematically and thoroughly.

### **1.1. Human energy needs**

Nutrition is absolutely essential to all living creatures. Human existence has been sustained by constant reception of substances from external environment (food, drink). In the middle of 19<sup>th</sup> century, Liebig analyzed food samples and realized that they had three basic organic substances, namely protein, carbohydrate, lipid and some other inorganic ones (mineral) (Liebig and Gregory, 1842).

It was not until the early 20th century, Voit (1877) and Rubner (1883; 1884) independently measured caloric energy expenditure in different species of animals, applying principles of physics in nutrition. Hopkins (1912) recognized the important role of vitamins to human life. Thermogenesis was used to measure the amount of energy expended. In general, the total energy of body expands on three main categories including 50-65% basal metabolism, 30-50% physical activities and 10% thermic effect of food. The energy expenditure during one day differs for each person. It was these organic substances that provide adequate amount of energy for our body. The more the body moves, especially in case of manual labor, the more energy will be consumed. The remaining 75% of energy generated during muscle movement will be emitted as heat. Consumed energy will be calculated via kilocalories (Kcal): Kcal per 1 kg/minute (or during an hour). If the mean energy consumption in the basal metabolic process is 1 Kcal/kg/hour (Kunii et al., 2005).

- When sitting still: 1.4 Kcal
- When standing without stretching: 1.5 Kcal
- When working mildly (white-collar workers, tailors, mechanics, teachers): 1.8-2.5 Kcal
- When moving muscles slightly with body movement (doctors, technicians, post officers, air hostesses): 2.8 -3.2 Kcal
- When working moderately (mechanics, painters, farmers, bearers): 3.2- 4 Kcal
- When working intensively (miners, excavator drivers, bulldozer drivers, bearers at the port, tank soldiers): 5.0 – 7.5 Kcal/kg/h

In general, while a person with mild to moderate labor consumes around 2300 – 3000 Kcal/day, an intensively working person might consume from 3000 to 4000 Kcal/day (Ha H.K., 1998).

Two basic components of human nutritional need are macronutrients, consisting of carbohydrates, proteins, lipids (fats and oils) and water, and micronutrient, including vitamins, minerals, and trace elements. Apart from minerals and vitamins, the average energy consumed of a hard working young person per day is around 3000 Kcal, thus the carbohydrate intake must be 400 – 500g. An average minimum lipid intake of 60g must be ensured, of which 30 – 50% is derived from animals. The amount of protein must be maintained around 80 – 100g, completely satisfying human needs in normal condition and in slight labor. In case of intense labor, there must be an increase in the amount of protein (approx. 150-160g), in which animal lipid might account for 30% (Ha H.K., 2002a).

According to the Institute of Nutrition – Ministry of Health (2003), the adult energy need is as follows:

**Table 1.1. Adult energy needs**

<b>Gender</b>	<b>Age</b>	<b>Mild labor (Kcal/day)</b>	<b>Moderate labor (Kcal/day)</b>	<b>Intense labor (Kcal/day)</b>
Male	18 - 30	2300	2700	3300
	30 - 60	2200	2600	3200
	> 60	1900	2200	
Female	18 - 30	2200	2300	2600
	30 - 60	2100	2200	2500
	> 60	1800		

*\*Source: (Ministry of Health, 2000)*

According to World Health Organization, it is possible to calculate the daily energy needs from basic metabolic needs via such coefficients mentioned in table 1.2 and 1.3.

**Table 1.2.** Basal metabolic rate via weight calculator

Age group	Basal metabolic rate (Kcal/day)	
	Male	Female
18 – 30	15,3 x W + 679	14,7 x W + 496
30 – 60	11,6 x W + 879	8,7 x W + 829
Over 60	13,5 x W + 487	10,5 x W + 596

\* Source: (Ha H.K., 2002a).

- W: Body weight (kg)

**Table 1.3.** The coefficient of the adult energy needs from the basal metabolism

Sort of labor	Male	Female
Mild labor	1,55	1,56
Moderate labor	1,78	1,61
Intense labor	2,10	1,82

\* Source: (Ha H.K., 2002a).

From Table 1.2, we are able to calculate basal metabolic rate of a group aged from 18 to 30, male, mean weight of 50kg, moderate labor, which is as follows:

$$(15,3 \times 50) + 679 = 1444 \text{Kcal}$$

From Table 1.3, we could find the corresponding coefficient for moderate labor in male, namely 1.78, and could calculate the daily energy:

$$1444 \times 1,78 = 2570 \text{ Kcal}$$

### **1.1.1. Daily protein requirements for adults:**

In 1985, a group of experts of the World Health Organization (WHO) and the Food and Agriculture Organization (FAO) reviewed the results of the study on nitrogen balance and came to the conclusion that an adult protein requirements of 0.75g are considered safe by protein of cow's milk or eggs per day for 1kg for both sexes (World Health Organization, 1985). It was also mentioned in Recommendations of the National Research Council (1989).

In fact, we eat a variety of plant-based foods, which have a much lower bioavailability than eggs and milk, therefore the actual protein needs from safety needs are often calculated as follows:

$$\text{Actual protein needs} = \frac{\text{Safety need based on standard protein}}{\text{Actual protein quality index}} \times 100$$

According to the research of the Viet Nam National Institute of Nutrition (Ha H.K., 2002b), the protein utilization index in the diet commonly found in our country is around 60%, so the actual protein requirement will be

$$0,75/60 \times 100 = 1.25 \text{ g/kg/day}$$

The hygienists and physiologists showed that that the minimum requirement for protein was 1g per day per kilogram of body weight, energy provided from protein was at least over 9% of total caloric intake and 12% on average.

According to the Ministry of Health and the Vietnam National Institute of Nutrition, the daily protein requirement for adults aged from 18 to 60 years, for men is 60g, for women is 55g (Ha H.K., 2002b)

#### **1.1.2. Daily lipid requirement for adults:**

In adults, the demand of lipid needs to reach 15-20% of the serving's energy, with unsaturated fatty acids (linoleic acid) compulsorily occupied 4 - 10% of total energy, and saturated fatty acids accounted for no more than 10% of energy. (Recommendation of Vietnam National Institute of Nutrition, Ministry of Health (2000)

#### **1.1.3. Daily carbohydrate requirement for adults:**

A required energy-balanced serving of glucose compared to protein and lipid is 66-70%. According to Ha H.K. (2002a) a balanced diet of energy needs a ratio of protein : lipid : carbohydrate # 14: 20: 66.

Based on database about human nutrition from WHO, Mann et al. (2007) found that range for dietary carbohydrate intake was 55–75% total energy. Elia and Cummings (2007) showed that the ratio of carbohydrate, protein and fat were required respectively 17: 17: 37 kJ/g in the balance diet.

#### **1.1.4. Minerals and vitamins requirement:**

The needs of minerals and vitamins in adults are presented in table 1.4 below:

**Table 1.4.** The adult need of minerals and vitamins

<b>Adult (labor)</b>	<b>Ca (mg)</b>	<b>Fe(mg)</b>	<b>A (mcg)</b>	<b>B1 (mg)</b>	<b>B2 (mg)</b>	<b>PP (mg)</b>	<b>C (mg)</b>
Male 18 - 30	500	11	600	1,2	1,8	19,8	75
30 - 60	500	11	600	1,2	1,8	19,8	75
> 60	500	11	600	1,2	1,8	19,8	75
Female 18 - 30	500	24	500	0,9	1,3	14,5	70
30 - 60	500	24	500	0,9	1,3	14,5	70
> 60	500	9	500	0,9	1,3	14,5	70

\* Source: (Ha H.K., 2002b)

## 1.2. Some biological indicators assessing nutritional status.

### 1.2.1. Morphological indicators:

**Stand height:** Stand height is one of the most commonly used dimensions in the basic morphological, anthropological, and medical surveys. Height representing the stature of man depends on factors such as anthropology, sex (Nguyen Quang Quyen, 1978).

According to the aggregate statistics of various races in the world, the average height is 135-190 cm. Being beyond the upper limit is considered as abnormality anthropometers have classified the height of human beings in general as follows:

- Low type: height <160 cm.
- Medium type: 160 cm ≤ height ≤ 170 cm.
- High type: height > 170 cm.

The average height of Vietnamese women is 150 ± 4.20 cm, and Vietnamese men is 160 ± 4.80 cm. In general, the Vietnamese height is lower than the world average (Le N.T., 2000).

- **Body weight:** Body weight does not totally reflect the stature, but it is related to other dimensions, as a result, all nutrition studies do focus on the weight of the body. However, the accuracy of the weight is not high as it varies depending on the timing of the measurement. In general, the Vietnamese are relatively light, with average weight at 18-25 years of age is 45 ± 4kg for women and 55 ± 4kg for men.

It was found out that being too light weight or overweight was associated with morbidity and mortality (Ha H.K., 2002b).

There are many calculators for “ideal” weight (Ha H.K., 2002b)

- Broca formula: "ideal" weight (kg) = height (cm) -100

- Lorentz formula for "ideal" weight:

$$(Kg) = \text{height (cm)} - 100 - (\text{height} - 150) / 4$$

- Bongard formula:

"Ideal weight":

$$(\text{kg}) = \text{height (cm)} \times \text{chest circumference (cm)} / 240$$

- Formula of the US insurance agency:

$$\text{"Ideal" weight} = 50 + 0,75 \times (\text{height} - 150)$$

#### - **Body Mass Index (BMI):**

BMI calculation formula:

$$\text{Weight (kg)} / [\text{height}]^2 (\text{m})$$

The body mass index relatively accurately estimates the nutritional status of the body.

In addition to height and weight, the BMI also depends on factors such as age, sex, nutritional status, race, geographic region, socioeconomic conditions (Keys et al., 1972).

### **1.3. Physiological and biochemical indicators related to cardiovascular function**

#### - **Physiological parameters:**

*Arterial blood pressure:* According to Duc (1996) the boundary between normal and hypertensive people is difficult to determine.

To detect hypertension, blood pressure (BP) should be measured at least twice a day with the same sphygmomanometer, the same person who measures.

According to the database of the American Heart Association, Systolic Blood Pressure (SBP) less than 120mmHg and Diastolic Blood Pressure (DBP) less than 80 mmHg are considered normal blood pressure.

SBP from 120 to 139 mmHg or DBP from 80 to 89 mmHg are considered as prehypertension.

SBP from 140 to 159 mmHg or DBP from 90-99 mmHg are considered high blood pressure (Hypertension) stage 1.

SBP of 160mmHg or higher, or DBP of 100 mmHg or higher are considered high blood pressure (Hypertension) stage 2.

SBP of higher than 180 mmHg or DBP of higher than 110 mmHg are considered hypertensive crisis (emergency care need).

According to Le N.T. (2000), before year 1975, mean SBP of the average

Vietnamese > 15 years was 110mmHg with a range of 90-140mmHg and average DBP of 70mmHg with a range of 50 - 90mmHg, After 20 years, blood pressure of Vietnamese people increased 4.2 mmHg for SBP and increased 2.4 mmHg for DBP. In Europe and North America, the proportion of people with high blood pressure accounts for 15-20% of the population. In Tran T.V. and et al (1995), in a randomly selected population of 10 randomized studies, the percentage of people with hypertension was 5.28%, of which 2.87% had a borderline hypertension, 2.4% actual hypertension..

**- Biochemical parameters:**

According to (Sorrentino Mathew, 2001), nowadays, in developed countries, the mortality rate of cardiovascular diseases is high, especially due to atherosclerotic diseases such as coronary artery disease and stroke. In USA, the mortality rate of atherosclerosis in the 50 to 54years age group is 467/10,000 and in the group of 60 - 64 years old is 1157/10,000. The annual number of deaths from myocardial infarction is 650.000, accounting for 50% of death cases over 40 years of age (Mai, 1984). Based on German Federal Statistical Office (2011) in Germany, cardiovascular disease was cause of death of more than 340.000 people in 2011.

According to WHO's database (2007), raised cholesterol was one of leading cause of disease burden which caused 2.6 million deaths and 29.7 million disability adjusted life years. It found that the global prevalence of raised total cholesterol among adults was 39% (37% for males and 40% for females) in 2008. In the United States, nearly 31 million adults had a total cholesterol level greater than 240 mg/dL and 73.5 million adults (31.7%) have high low-density lipoprotein (LDL) (Mozaffarian et al., 2015).

**Table 1.5.** Guidance parameters monitoring the status of blood lipids

Parameters	Concentration	Normal	Suspected	Treatment
Triglycerid	mmol/l	< 1.7	1.7 - 2.3	> 2.3
Total cholesterol	mmol/l	< 5.17	5.17 - 6.7	> 6.7
LDL - cholesterol	mmol/l	< 3.9	3.9 - 4.9	> 4.9
HDL - cholesterol (Male)	mmol/l	> 1.4	0.9 - 1.4	< 0.9
HDL - cholesterol (Female)	mmol/l	> 1.7	1.2 - 1.7	< 1.2

\*\* Source: (Le D.T., 1995)

Apo lipoprotein normal ranges:



- Apo lipoprotein A1 (ApoA1) 110 - 160mg/100ml

- Apo lipoprotein B (Apo B) 130/100ml

Apo B/Apo A1 ratio = 0.66

**- Glucose level:**

Fasting glucose level of a healthy person, who has a balanced dietary intake of 250 - 300g carbohydrates per day, is somewhere in the vicinity of 4 - 6 mmol/l (0.7 - 1.1 g/l) (Le D.T., 1995).

## **1.4. Metabolic syndrome**

### **1.4.1. History of studies on metabolic syndrome:**

The history of metabolic syndrome was related to an Italian physician and anatomist. At about 250 years ago, the association between atherosclerosis, hypertension, visceral obesity, high level of uric acid in the blood and the frequent respiratory disorders during sleep: the obstructive apnea were revealed by Morgagni (1762). However, Metabolic syndrome was considered as first mention by Kylin (1923) when he found that many cardiovascular risk factors were strongly associated to each other (hypertension, hyperglycemia, obesity and high uric acid in adult).

In 1927, Maranon, a Spanish endocrinologist, identified arterial hypertension as pre - diabetic stage and also applied this concept for obesity. Maranon strongly supported the theory that food played an important role on preventing and treating these health issues (Milici, 2010).

Himsworth (1936) was the first author who classified diabetes patients into insulin – sensitive group and insulin- resistant group.

Vague (1947) firstly identified android obesity, the obesity pattern was associated mostly with diabetes mellitus and cardiovascular diseases

During the 1960's and 1970's, many authors (Albrink et al., 1962; Camus, 1966; Hanefeld, 1973) found the often-simultaneous presence of obesity, hyperlipidemia, diabetes mellitus and arterial hypertension. Especially, Avogaro et al. (1967) named this cluster syndrome firstly as plurimetabolical syndrome.

Hanefeld (1981) described the syndrome of diabetes mellitus, hyperinsulinism, obesity, hypertension, hyperlipidemia, and atherosclerosis related to genes, high nutritious diet and physical inactivity.

Reaven (1988) named the syndrome X including glucose intolerance, hyperinsulinism, high LDL-Cholesterol and triglyceride, low HDL-Cholesterol, high total-cholesterol and hypertension, the major cause of these disorder was insulin resistance. His hypothesis was that metabolic syndrome represented a complex

disorder of the energetic metabolism which has close connection with insulin secretion altering, influenced in its turn by the sensitivity/ resistance to insulin.

The danger of central obesity in metabolic syndrome was emphasized by Kaplan (1989) and was called by the term Deathly Quartet with central obesity, glucose intolerance, hypertriglyceride and hypertension.

DeFronzo and Ferrannini (1991) and Haffner et al. (1992) identified insulin resistance was the main cause of metabolic syndrome.

Nowadays, syndrome X or metabolic syndrome has become the topic of many studies.

#### **1.4.2. Nomenclature**

In the past, many nomenclature were used to reflect the author's view and characteristics of metabolic syndrome. The different theories led to different diagnosis criteria and name of this syndrome according to author's identification of the major factor below as:

Paulescu N (1920) said "most frequently, the obese people become glycosuric, as if the two affections (obesity and fat diabetes) represent two consequent phases of the same pathological process".

Avogaro et al. (1967): Plurimetabolic syndrome

Reaven (1988): insulin resistance was the major element so the syndrome was named as insulin resistance syndrome

Kaplan (1989): Deathly quartet including central obesity, glucose intolerance, hypertriglyceride and hypertension.

Ferrannini et al. (1991): hypeinsulinism was the key element of metabolic and cardiovascular syndrome.

Zimmet (1993): hyperinsulinism syndrome.

Bouchard et al. (1993): genes caused the metabolic disorders included diabetes, obesity and hyperlipidemia.

In 1999, World Health Organization (WHO) unified all definitions and used term "metabolic syndrome". This definition emphasized the important role of dangerous disorders to the patients included abdominal obesity (central obesity); glucose intolerance, hyperglycemia, hypertriglyceride, and microalbuminuria (W.H.O, Consultation, 1999).

European group for the Study of Insulin Resistance (EGIR) in 1999; The USA Cholesterol Panel, Adult Treatment Panel III ( NCEP-ATP III) in 2001 and American

College of Endocrinology (2003) also gave their own definitions.

In 2005, The International Diabetes Federation (IDF) published its criteria for metabolic syndrome based on the modification of NCEP- ATP III definition and included the following criteria: central obesity, hyper- triglyceride, hyperglycemia, low HDL-Cholesterol and hypertension. IDF defined the central obesity as key element, the other factors were additional elements.

In 2009, A Joint Interim statement of International Diabetes Federation Task Force on Epidemiology and Prevention; National Heart, Lung, and Blood Institute; American Heart Association; World Heart Federation; International Atherosclerosis Society; and International Association for the Study of Obesity to define the criteria for diagnosing metabolic syndrome; this definition has been widely accepted in recent years.

**1.4.3. Criteria for diagnosing the metabolic syndrome:**

There are several definitions/criteria for the metabolic syndrome such as definitions from the WHO, NCEPT – ATP III and IDF. This heterogeneity in the definitions makes it difficult to compare individual studies to each other.

In 1999, WHO firstly formulated the definition of metabolic syndrome. This definition focused on the presence of type 2 diabetes combined with other parameters: hypertension, increased level of blood lipids, obesity and micro-albuminuria.

**Table 1.6.** *The WHO definition of Metabolic Syndrome*

Diabetes mellitus/ Impaired fasting glucose* / Impaired Glucose Tolerance** / insulin resistance (evaluated by the euglycemic clamp method)
<b>AND</b> at least 2 of the following parameters:
BMI> 30 kg/m <sup>2</sup> or waist/ hip ratio > 0,90 for men; >0.85 for women
Plasmatic triglyceride (TG) ≥ 150 mg/dl ( >1.7 mmol/l) or HDL-Cholesterol <35 mg/dl (0.9 mmol/l) in men; <39 mg/dl (1.0 mg/dl) in women
The rate of excretion off the urine albumin >20 µg/min or albumin /creatinine ration ≥ 30 mg/l
Blood pressure ≥ 140/90 mmHg

Source: (W.H.O, Consultation, 1999)

\**Impaired Fasting glucose (IFG)= (basal) fasting glycemia modified/ affected (110-125 mg/dl) (OMS classification 1998).*

\*\* *Impaired Glucose Tolerance (IGT) = tolerance altered to glucose (glycemia at 2*

hours after oral intake with 75g of glucose (140-199 mg/dl)- WHO classification 1980, 1985).

Also, in 1999, European Group for the Study of Insulin resistance (EGIR) revised the WHO definition, establishing the definition of which insulin-resistance is the principal cause of this syndrome. In the EGIR definition, the abdominal obesity was considered more important than in WHO definition, but the patients with diabetes mellitus type 2 was not mentioned.

**Table 1.7. EGIR definition of the Metabolic Syndrome**

Insulin-resistance or fasting hyper - insulinemia >25%
<b>AND</b> at least, 2 of the following parameters:
Plasmatic fasting glucose $\geq$ 6.1 mmol (excluding diabetes)
Blood pressure $\geq$ 140/90 mmHg or treatment for HTA
Plasmatic triglycerides $\geq$ 2 mmol /l or HDL cholesterol $<$ 1 mmol/l or treatment for dyslipidemia
Waist circumference $\geq$ 94 cm for men and $\geq$ 80 for women.

Source: (Balkau and Charles, 1999)

In 2001, NCEP-ATP III (the USA Cholesterol Education Panel, Adult Treatment Panel III) introduced alternative clinical criteria for defining MS. The ATP III criteria don't require the demonstration of the insulin-resistance presence.

**Table 1.8. NCEP- ATP III definition of Metabolic Syndrome**

At least 3 of the following parameters:
Waist circumference $>$ 102 cm for men and $>$ 88 cm for women
Plasma Triglycerides $\geq$ 150 mg/dl ( $>$ 1.7 mmol/l)
HDL cholesterol $<$ 40 mg/dl (1.0 mmol/l) in men and $<$ 50 mg/dl (1.3 mmol/l) in women
Blood pressure $\geq$ 130/85 mmHg
Serum glucose $\geq$ 110 mg/dl ( $>$ 6.1 mmol/l)

Source: (Expert Panel on Detection, 2001)

In 2003, American College of Endocrinology (AACE) modified the NCEP-ATP III criteria with the involving of insulin-resistance. The major criteria were: IGT or IFG, increased triglycerides, low HDL-cholesterol, higher blood tension and obesity. Based on AACE definition, the diagnostic of metabolic syndrome is no longer applied when type 2 diabetes is diagnosed.

**Table 1.9.** AACE (American College of Endocrinology) definition of Metabolic Syndrome

<p><b>The presence of at least 1 factor out of the following:</b></p> <ul style="list-style-type: none"> <li>- Diagnosis of cardiovascular diseases, hypertension, polycystic ovary syndrome, nonalcoholic fatty liver or acanthosis nigricans disease</li> <li>- Family history of type 2 diabetes mellitus, hypertension or cardiovascular diseases</li> <li>- Gestational diabetes history or intolerance to glucose</li> <li>- Non-Caucasian ethnic</li> <li>- Sedentariness</li> <li>- BMI &gt; 25 kg/m<sup>2</sup> and/or waist circumference &gt; 102 cm for men and &gt; 88 cm for women</li> <li>- Age &gt; 40 years.</li> </ul>
<p><b>And at least 2 out of the following parameters:</b></p> <ul style="list-style-type: none"> <li>- Plasmatic triglycerides (TG) ≥ 150 mg/dl</li> <li>- HDL cholesterol &lt; 40 mg/dl in men and &lt; 50 mg/dl in women</li> <li>- Blood pressure ≥ 130/85 mmHg</li> <li>- Fasting glucose 110 – 125 mg/dl or at 2 h postprandial 140 – 200 mg/dl (diabetes is excluded from the AACE definition)</li> </ul>

Source: (Einhorn, 2003)

In 2005, the new criteria based on revision of ATP III definition that was revealed by the International Diabetes Federation (IDF). Four factors were required to having diagnosis with the metabolic syndrome (I.D.F, 2005).

**Table 1.10.** The IDF definition of Metabolic Syndrome (2005)

<p>The central obesity (defined by the waist circumference ≥ 94 cm for men and ≥ 80 cm for women, of European origin, with characteristics values for various ethnic groups) and ≥ 2 of the following parameters:</p>
<p>Low level of the TG ≥ 1.7 mmol/l (150 mg/dl) or drug treatment for hyperlipidemia</p>
<p>Low level of the HDL – cholesterol &lt; 1.03 mmol/l (40 mg/dl) in men and &lt; 1.29 mmol/l (50 mg/dl) in women or drug treatment for dyslipidemia</p>
<p>Arterial hypertension, systolic blood pressure ≥ 130 mmHg or diastolic blood pressure ≥ 85 mmHg or cure for hypertension that was previously diagnosed</p>
<p>The increased levels of the venous glycemia ≥ 5.6 mmol/l (100 mg/dl) or previously diagnosed type 2 DM (with values &gt; 5.6 mmol/l or 100 mg/dl, there is recommended an oral test of tolerance to glucose, but it isn't needed for defining the MS presence).</p>

Source: (I.D.F, 2005)

In 2009, IDF and AHA/NHLBI showed the different clinical definitions (Alberti et al., 2009)

At this year, the International Diabetes Federation and the American Heart Association/ National Heart, Lung and Blood Institute (AHA/NHLBI), World Heart Federation (WHF), International Atherosclerosis Society (IAS); and International Association for the Study of Obesity (IASO) showed the different clinical diagnosis of MS (Alberti et al., 2009).

**Table 1.11. Criteria for Clinical Diagnosis of the Metabolic Syndrome Measure**

	<b>Categorical Cut Points</b>
Elevated waist circumference	Population- and country-specific definitions
Elevated triglycerides (drug treatment for elevated triglycerides is an alternate indicator†)	≥150 mg/dL (1.7 mmol/L)
Reduced HDL-C (drug treatment for reduced HDL-C is an alternate indicator†)	<40 mg/dL (1.0 mmol/L) in males; <50 mg/dL (1.3 mmol/L) in females
Elevated blood pressure (antihypertensive drug treatment in a patient with a history of hypertension is an alternate indicator)	Systolic ≥130 and/or diastolic ≥85 mm Hg
Elevated fasting glucose‡ (drug treatment of elevated glucose is an alternate indicator)	≥100 mg/dL
HDL-C indicates high-density lipoprotein cholesterol.	
Source: (Alberti et al., 2009)	

Alberti et al. (2009) identified that waist measurement was as a simple screening tool. Moreover, different ethnic groups have different waist measurement scale.

**Table 1.12. Current recommended Waist Circumference Thresholds for Abdominal obesity by Organization**

Population	Organization	Recommended Waist Circumference Thresholds for Abdominal obesity	
		Men	Women
Europid	IDF[1]	≥ 94 cm	≥ 80 cm
Caucasian	WHO[2]	≥ 94 cm (increased risk)	≥ 80 cm (increased risk)
		≥ 102 cm (still higher risk)	≥ 88 cm (still higher risk)

United States	AHA/NHLBI (ATP III)[3]	≥ 102 cm	≥ 88 cm
Canada	Health Canada [4]	≥ 102 cm	≥ 88 cm
European	European Cardiovascular Societies [5]	≥ 102 cm	≥ 88 cm
Asian (including Japanese)	IDF[1]	≥ 90 cm	≥ 80 cm
Asian	WHO[2]	≥ 90 cm	≥ 80 cm
Japanese	Japanese Obesity Society [6][7]	≥ 85 cm	≥ 90 cm
China	Cooperative Task Force[8]	≥ 85 cm	≥ 90 cm
Middle East, Mediterranean	IDF[1]	≥ 94 cm	≥ 80 cm
Sub – Sahara African	IDF[1]	≥ 94 cm	≥ 80 cm
Ethnic Central and South American	IDF	≥ 90 cm	≥ 80 cm

Source: [1](Grundy, 2005) [2](Organization, 2000) [3](Health, 1998) [4](Khan et al., 2006) [5](Graham et al., 2007) [6](Oka et al., 2008) [7](Circ, 2002) [8](Zhou, 2002)

The diagnosis of Metabolic Syndrome was identified based on complex criteria. Therefore, Kahn et al. (2005) presented that it need to clarify of the existing definition of Metabolic syndrome including: having ambiguous or incomplete definition of MS, having different definition of MS from the list criteria, and having a relationship between the syndrome component and insulin resistance.

Generally, it is needed to have more subsequent and thorough- going studies on metabolic syndrome and its diagnostic definition in order to optimize its predictive value.

#### **1.4.4. Epidemiology of metabolic syndrome**

Nowadays, metabolic syndrome is considered one of the most important medical problems worldwide.

Recent studies showed that approximately 20-25% of the total world population have a metabolic syndrome (Milici, 2010). Such heavily burden of diagnosis and treatment for a large number of patients with metabolic syndrome give a lot of difficulties

for the healthcare system all over the world in both developed and developing countries. Delaying treatment of metabolic syndrome will lead to an increasing prevalence of cardiovascular diseases and type 2 diabetes from which further complications can arise.

#### *1.4.4.1. Studies on the prevalence of metabolic syndrome in the world:*

A cohort study in Thailand (Tanomsup et al., 2007) on 3,499 Thai adult aged 35-54 years from 1985 to 2002 used the NCEP-ATP III and IDF criteria for diagnosing metabolic syndrome. In 1985, the prevalence of metabolic syndrome by NCEP – ATP III and IDF criteria was 19.3 % and 11.7% in men and 11.8% and 10.3% in women, respectively.

According the survey from 2003 to 2012 in the United States, prevalence of the metabolic syndrome was higher (95% CI, 32.5%-33.5%). The prevalence in women was higher than in men (35.6% vs 30.3%, respectively,  $P < .001$ ). Hispanics group was the highest prevalence of the metabolic syndrome (35.4%; 95% CI, 34.2%-36.6%), non-Hispanic whites (and blacks were lower (33,4% ;32.7%) (Aguilar et al., 2015).

A cross- sectional survey used Singapore National Health Survey data (1998) to estimate the prevalence of the metabolic syndrome in Asian population include Chinese, Malay, and Asian-Indian ethnicity with aged from 18 to 69 years. National Cholesterol Education Program Adult Treatment Panel III (NCEP ATP III) criteria with and without the modified waist circumference criteria for Asian population (waist circumference  $>80$  cm in women and  $>90$  cm in men) was used to define the metabolic syndrome. As a result, the crude prevalence of the metabolic syndrome ranged from 12.2 to 17.9%. The prevalence of the metabolic syndrome increased from 2.9% in subjects aged 18-30 years to 31.0% in subjects aged 60-69 years by using the modified Asian criteria for waist circumference. The authors found that metabolic syndrome was more common in men than in women (20.9% versus 15.5% ;  $P < 0.001$ ) and Asian Indians (28.8% in Asian-Indians, 24.2% in Malays, and 14.8% in Chinese;  $P < 0.001$ ) (Tan et al., 2004).

Isomaa et al. (2001) aimed to estimate the prevalence and cardiovascular risk associated with metabolic syndrome in 4,483 subjects aged 30-70 years living in Finland and Sweden. The cohort was divided into 3 groups including normal glucose tolerance, impaired fasting glucose (IFG)/impaired glucose tolerance(IGT) and type 2 diabetes. In men and women, the prevalence of metabolic syndrome was seen in 10% and 15 % of subjects with normal glucose tolerance; 42 % and 64% of participants with IFG/IGT; and 78% and 84 % of those with type 2 diabetes.



In Tehran Lipid and Glucose Study (Azizi et al., 2003) on 10,368 subjects (4,397 men and 5,971 women) aged 20 years and over, the unadjusted prevalence of metabolic syndrome in the study population was 30.1% (CI 95%: 29.2-31.0) and age-standardized prevalence was 33.7% (CI 95%: 32.8-34.6) by the NCEP definition: the presence of three or more of the following components: abdominal obesity, hypertriglyceridemia, low HDL-C, high blood pressure, and high fasting glucose. This study also showed the relation of metabolic syndrome with age and gender: the prevalence of metabolic syndrome was increasing with age and more commonly occurred in women than in men (42% vs. 24%,  $p < 0.001$ ). Low HDL-C was the most common metabolic abnormality in both male and female subject.

A study of Gupta et al. (2003) also implemented in an urban Indian population (1,800 subjects including 960 men and 840 women) aged 20 years and over showed the prevalence of metabolic syndrome with age-adjusted of 7.9% in men (CI 6.7-9.1) and 17.5% in women (CI 14.4-20.6) and overall prevalence of 12.8% (CI 10.8-14.8). The metabolic syndrome (called as insulin resistance syndrome) was defined when any three of-IFG, high triglycerides  $>150$  mg/dl, low HDL cholesterol (men $<40$  mg/dl, women $<50$  mg/dl), central obesity (men $>102$  cm, women $>88$  cm), or high normal blood pressure ( $>130/>85$  mmHg) or hypertension-were present.

Oh et al. (2004) studied on an urban Korean population of 269 men and 505 women (aged 30–80 years). The authors applied NCEP –ATP III definition to explore the prevalence and pattern of metabolic syndrome and its association with hyperinsulinemia. The study results showed that prevalence of metabolic syndrome was 16.0% in men and 10.7% in women with NCEP-ATP III criteria. However, when the authors applied the adjusted - criteria for waist circumference (90 cm in men and 88 to 80 cm in women), the prevalence of the metabolic syndrome increased to 29.0 and 16.8%, respectively.

The National Health and Nutrition Examination Survey (Ford, 2005) studied the prevalence of the Metabolic Syndrome among adults in the US using IDF and NCEP criteria during the period of 1999-2002. With a total population of 3,601 men and women aged  $\geq 20$  years, the unadjusted prevalence of metabolic syndrome by NCEP definition was  $34.5 \pm 0.9\%$  in total population,  $33.7 \pm 1.6\%$  in men, and  $35.4 \pm 1.2\%$  in women; the unadjusted prevalence by the IDF definition was  $39.0 \pm 1.1\%$  in total population,  $39.9 \pm 1.7\%$  in men, and  $38.1 \pm 1.2\%$  in women. To be adjusted by age, the prevalence of metabolic syndrome findings was 24.0 and 23.4% in men and women,

respectively; age-adjusted prevalence of central obesity were 30.5 and 43.5% in Caucasian men and women, 23.3 and 62.1% in African- American men and women, and 30.6 and 62.7% in Mexican-American men and women, respectively.

Gu et al. (2005) studied 15,540 Chinese subjects aged 35-74 years in 2000-2001 and found the age- standardized prevalence of metabolic syndrome among adults in China was 9.8% in men and 17.8% in women with the diagnosis criteria from the guidelines of US National Cholesterol Education Program (NCEP).

Patel et al. (2006) used the NCEP-ATPIII criteria to diagnose the metabolic syndrome in the US and selected Asian populations. The data was collected from national investigation in Hong Kong, Taiwan, Thailand and the US with selected population aged 35 years and over. The authors found that the age-standardized prevalence of was highest in the US population (31% in men, 35% in women), and lowest in Taiwan (11% in men, 12% in women).

In 2009, Delavari A et al published the findings of the first Nationwide Study of the Prevalence of the Metabolic Syndrome and optimal cutoff point of Waist Circumference in the Middle East, a part of The National survey of Risk factors for Non-Communicable Diseases of Iran. By this study, the authors compared the prevalence of metabolic syndrome of a population of 3,024 Iranians aged 25-64 years by different criteria: NCEP –ATPII, IDF, and the modified definition of NCEP –ATP III, AHA/NHLBI. They found that age- standardized prevalence of metabolic syndrome was about 34.7% (ATP III criteria); 37.4% (IDF criteria), and 41.6% (NCEP –ATP III, AHA/NHLBI criteria). The cutoff point of waist circumference in Iranians was 89 cm for men and 91cm for women. The prevalence of metabolic syndrome was increased by age, women, urban areas. (Delavari et al., 2009)

#### *1.4.4.2. In Vietnam:*

In Vietnam, studies on the prevalence of metabolic syndrome are sparse and usually focus on certain patient groups (patients with obesity, hypertension, menopause, etc). The reported prevalence of metabolic syndrome ranges from 8 – 40 % from the Central to the South of Vietnam. Kunii et al. (2005) revealed that the prevalence of metabolic syndrome in Vietnamese adults who lived in urban areas was 18.5% (95% CI: 15.5–21.9).

Binh et al. (2014) conducted the study to estimate the prevalence of MetS among rural middle-aged population in Vietnam. The finding showed that the total age- and sex-adjusted prevalence of metabolic syndrome was 16.3%. The most frequent component of metabolic syndrome was high triglycerides (43.2%), followed by low HDL-C (42.0%), elevated blood pressure (29.2%), high plasma glucose (14.3%), and central

Physical inactivity  
Ageing  
Genetics (12.3%). More than 40% total population had at least two MS components.

Endocrinological  
factor  
Metabolic Risk  
A study of in central obesity population in Hue city (1999-2000) found that the prevalence of metabolic syndrome was 44% (male: 29.1%; female 75%) and 83.9% among participant with BMI > 25. A similar study in Da nang city (2005-2006) showed that the prevalence of metabolic syndrome was 48%.

In 2008, an epidemiological study on 1.471 subjects of Thua Thien Hue province identified the prevalence of metabolic syndrome was 8,4% among men and 14,1% among women; 21.2 % in women aged 50-59 years, 30.4% in women aged 60-69 years and 36.9% in women ≥ 70 years.

The prevalence of metabolic syndrome in patients with type 2 diabetes was 87.9% in Hue city, 77.6 % (by NCEP-ATP III) and 86% (modified NCEP-ATP III) in Hochiminh city, 72.9% in Danang city, 65.1% in Binh dinh province.

Hypertensive patients had the prevalence of metabolic syndrome ranged between 41.2 and 53% by NCEP-ATP III criteria. A study in Tra Vinh province used IDF criteria for hypertensive patients aged 40 and over showed the prevalence of metabolic syndrome was 28. 2%.

In the group of stroke patients, the prevalence of metabolic syndrome also was high (30-52%).

#### 1.4.5. The pathogenesis mechanism of metabolic syndrome

Metabolic syndrome is defined as a cluster of metabolic abnormalities related to insulin resistance and commonly appeared on people with overweight/ obesity (Kahn et al., 2005). The major cause of metabolic syndrome still be challenged the researchers. However, most of researchers/ scientists agreed that insulin resistance and central obesity were significant pathogenesis factor (Diagram 1.1.) (Grundy et al., 2004; Alexander et al., 2003).

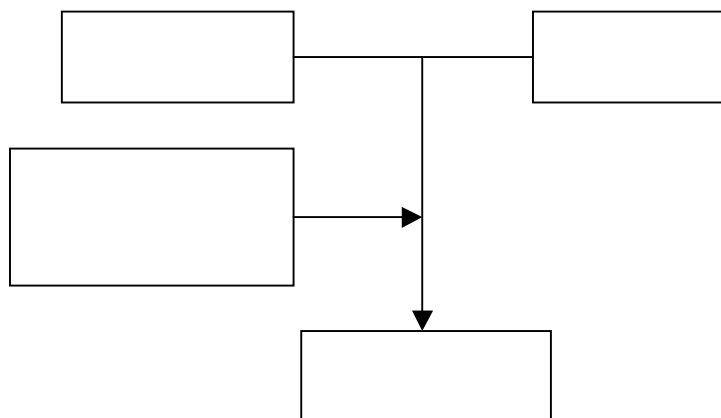

**Diagram 1.1: Etiology of metabolic syndrome** (Grundy et al., 2004)

1.4.5.1. *Insulin resistance: linkage bridge between obesity and metabolic complications*

Insulin resistance including: genetic cell-targeted resistance, primary insulin resistance (metabolic syndrome, hypertension, polycystic ovary syndrome), secondary insulin resistance (obesity, type 2 diabetes, stress, pregnancy,...) (Nguyen H.T., 2008).

**Table 1.13.** *Abnormalities associated with insulin resistance/ hyperinsulinemia (Blaha and Elasy, 2006)*

Glucose metabolism disorders at different levels: Fasting glucose disorder Impaired glucose tolerance
Uric acid metabolism disorder: Hyperuricemia Decreased renal uric clearance
Dyslipidemia: Increased triglycerides, apo B Decreased HDL-Cholesterol Decreased size of LDL- particles Hyperlipidemia after meals
Hemodynamic: Increased activity of sympathetic nervous system Increased renal sodium retention Hypertension (50% of hypertensive patients had insulin resistance)
Coagulation: Increased PAI-1 Increased fibrinogen
Reproductive: Polycystic ovary syndrome

1.4.5.2. *Central obesity:*

Obesity was obviously indicated as a significant cause of diabetes, dyslipidemia and hypertension. Vague (1947) was the first author mentioned the term “anthropology obesity” (central obesity) and found out the strong relation between central obesity with the metabolic complications.

Based on the advanced imaging techniques, many studies proved that the

concentration of abdominal fat related to visceral fat accumulation and possible used to predict metabolic syndrome regardless BMI (Body Mass Index) value. Therefore, it helps to explain that why Reaven (1988) can detect insulin resistance in people with normal weight.

## **1.5. Vegetarian diet**

### **1.5.1. Definition:**

There are many ways to define the term vegetarian. According to the The Vegetarian Society (founded in 1847): "vegetarian" is derived from the Latin word *vegetus* meaning lively or vigorous. Oxford English Dictionary and other standard dictionaries state that the word was formed from the term "vegetable" and the suffix "-arian". Vegetarianism usually refers to a diet in which the food is derived from plants, with or without eggs, dairy products, and/or honey. There are many kinds of vegetarian diets:

**Ovo - lacto vegetarian:** eats plant products plus eggs and milk products. Most vegetarians in Western countries follow this diet as part of a healthy lifestyle. The diet consist of vegetables, beans, seeds, fruit and egg, milk, butter. This diet allows people to select many kinds of food so ovo-lacto vegetarian never face problems when they go to a restaurant. This is one of the most easy diets for many people to follow.

**Lacto- vegetarian:** eats plant and milk products. This diet is common in India. People choose this diet because they are afraid of egg product (rich in cholesterol), others use this diet for religious reason assuming that eggs are having a life.

**Pure vegetarian** who only consume food derived from plants. About 4 % of American vegetarians choose this diet. It is also very popular in Asian countries where Buddhism is common such as in China, Korea, Japan, Thailand and Vietnam. This diet is chosen for ethical considerations to save the life. Pure vegetarian or Buddhist vegetarianism excludes all animal products as well as vegetables of the allium family (which have the characteristic aroma of onion and garlic): onion, garlic, scallions, leeks, or shallots.

**Vegan or strict vegetarian diet:** excludes any use of any animal products for any purpose, including animal flesh (meat, poultry, fish and seafood), animal products (eggs, dairy, honey); the wearing and use of animal products (leather, silk, wool, lanolin, gelatin); also excludes animal use in entertainment, sport, research etc. The major vegan societies all disallow honey, but some "vegans" still use it. Some "vegans" also refuse to eat yeast products (Tam Dieu, 1999; Lee and Krawinkel, 2009).

## **1.5.2. Views on vegetarianism practice**

1.5.2.1. *Buddhist views on vegetarianism:* there are two major viewpoints representing two Buddhist schools of thought.

- *Theravada view on vegetarianism:* According to Theravada Buddhism, it is not which way you eat that matters as long as your method is flexibly conformable to the essence of dependent origination and can keep you healthy enough for Dharma practice. Vegetarianism, if results in a weak, pale body and a feeble mind, is nothing but a harmful act that can block Buddhism practice. Theravada Buddhists believe that vegetarianism did not exist in the early period of Buddhism and even the Buddha was not a vegetarian.

According to Theravada school, the Buddha did not lay much emphasis on eating meat or vegetables. This is because salvation does not lie in eating method but in the peace of the Three Vajras including body, speech and mind; One who eats vegetarian food but do bad deeds, speak dreadful words, nurture evil intentions and keep no commandments is not a true Buddhist practitioner. The Buddha and his disciples all followed mendicant traditions in eating: “eat to live, to practice (Buddhism)” not “live to eat, to enjoy”.

- *Mahayana view on vegetarianism:* Vegetarianism is not a typical characteristic or private property of Mahayana Buddhism in general and Chinese Mahayana Buddhism in particular. Especially, vegetarian did not originated from the time of the superior Buddhist monk Van The Chau Hoang. In fact, vegetarianism did appear when the Buddha was still alive and then it was significantly developed during the reign of King Asoka, an ancient Indian emperor who ruled the country from 274 to 232 BC, i.e. in the 3<sup>rd</sup> century BC.

In such period of time and until the 2<sup>nd</sup> century AD, Mahayana Buddhist was not established yet. During his reign over the Kingdom of India, as a Buddhist Emperor, Asoka used the quintessence of Buddhism and Buddha’s teachings as governing policies. This is evident in his order to construct numerous “pillars of life”, on which Buddhist commandments were carved. Among of them, there is one pillar with the words as follows: “Any life should not be fed to others. Even straws, if there are insects inside, should never be burned”.

Regarding Chinese Buddhism, Buddhism was first spread to this country in the 1<sup>st</sup> century AD. As a result, vegetarianism was also brought into use and experienced the rise and fall of Buddhism (Tam Dieu, 1999).

#### 1.5.2.2. Catholic view on vegetarianism:

Affected by Roman Catholic Church, Catholics also follow vegetarianism but their method is quite different from that of other religions such as Buddhism, Caodaism. Catholic vegetarianism means eating unsalted food, cereals and keeping off meat. Concurrently, Catholic vegetarians keep an austere and deprived diet with a purpose: *To remind the faithful that mankind is feeble and easy to become corrupted so we have to be modest in front of God and others, that we need to live a hard life in order to redeem our sins and that we need to strengthen our will so as to deal with temptations.*

In comparison with other religions, Catholicism has fewer vegetarian believers since its basic religious activity is not fasting but loving God and other people. Each Catholic has his own way to follow vegetarianism, depending on specific situations. Hard manual laborers, pregnant women and mothers who breastfeed their babies are advised to be careful in vegetarianism and get into charity work or help people instead.

Currently in Vietnam, a Catholic often spends only 2 days in a year on vegetarianism. The reason for this lies in the history of the country. In the past, Vietnamese people experienced terrible malnutrition due to long periods of war, poverty, famine and backwardness. Thus, the Catholic Church, with deep anxiety over the impacts of vegetarianism on people's nutrition, called upon their followers to limit fasting in order to protect their health for production (Tam Dieu, 1999).

#### 1.5.2.3. Cao Dai's and Hoa Hao's views on vegetarianism:

To the followers of Cao Dai and Hoa Hao, two religions deeply influenced by Buddhist viewpoints and thoughts, vegetarianism helps religious practitioners easily keep *the Five Precepts*: no killing, no stealing, no sexual misconduct, no lying, no intoxicants (alcohol, drugs). Vegetarianism is for cleansing body and purifying mind. In fact, food processed from animals is only nutritious towards human body, which is also flesh and blood. Vegetarian dishes, however, have two nutritional functions: they nourish bodies with mineral substances absorbed from the soil together with nitrogen from the air and at the same time fortify spirits thanks to the light and oxygen collected.

Eating vegetarian food is also a method to practice Mercy, Intelligence and Courage: not killing animals for food keeps one's soul merciful; not using flesh and blood for obtruding one's mind makes it bright; not letting one's self seduced by lust and indulgence fortify one's courage. Besides, vegetarianism helps with restraining Six Desires and Seven Emotions. The Six Desires include Desire to See (eyes), Desire to hear (ears), Desire to smell (nose), Desire to Taste (tongue), Desire to Touch (body)

and Desire to Think (mind). The Seven Emotions are Joy, Anger, Love, Hate, Grief, Fear and Desire.

Followers of Cao Dai and Hoa Hao also believe that vegetarianism helps them to escape retribution and samsara. Thus, they consider it as a self-practice method. In psychophysiological aspect, vegetarianism actually has many good effects on human life, both physically and spiritually, helping people to live their religious life in a purer and more peaceful manner (Tam Dieu, 1999).

### **1.5.3. Vegetarianism as a method for disease prevention and treatment:**

People who advocate this viewpoint argue that meat contains a lot of poisons that can cause cancer. This is because before getting killed, the animals suffer deep fear, which changes their inner biochemical systems and raises their hormones, especially adrenalin. A large quantity of hormones left in meat will poison human cells. As the American Academy of Nutrition and Dietetics emphasized: *“Animal meats are filled with poisoned blood and other residue”*.

In addition, some kinds of pesticide widely used in agriculture to kill insects such as DDT can be kept inside cattle fat and eventually absorbed by human bodies. A report of Iowa University has confirmed that most of DDT in our bodies is originated from meats. Further, the majority of diseases related to liver result from the overuse of food from animals, wines and musty food.

Another example is that after get slaughtered, animal meat will rapidly turn to ash-grey color. As a result, canned food producers add some nitrite, nitrate and other kinds of preservatives into the meat to create scarlet color, despite the fact that they can cause cancer. In countries where meals with much meat are preferred, the number of people with cancer of digestive system is high. Eating animal meat can also put people in the danger of getting mad cow disease as well as dangerous bacteria such as Salmonella, Campylobacter enteritis, E.coli...

Additionally, overeating meat can raise the rate to catch cardiovascular diseases such as atherosclerosis, high blood pressure, coronary, and cerebrovascular accident as there is a lot of cholesterol and saturated fatty acid in animal meat and fat. This substance, which is often stagnant on blood vessels can cause atherosclerosis, narrow arteries, weaken blood circulation, reduce the amount of blood to organs, cause necrosis and coronary, sometimes small blood clots that block blood vessels of brains. Furthermore, people who eat too much meat can easily catch kidney diseases, gout, arthritis, osteomalacia and poor excretion.



Craig and Mangels (2009) revealed that a vegetarian diet related to a lower risk of death from ischemic heart disease. This study showed that, it had lower low-density lipoprotein cholesterol levels, lower blood pressure, and lower rates of hypertension and type 2 diabetes in vegetarians than non-vegetarians. Furthermore, vegetarians tended to have a lower body mass index and lower overall cancer rates

Lanou and Svenson (2011) reviews current evidence regarding the relationship between vegetarian eating patterns and cancer risk. The result revealed that vegetarian diets were a useful strategy for reducing risk of cancer.

#### **1.5.4. Studies about Impact of vegetarian diet for health and health promotion**

A number of large scale studies have evaluated the effect of vegetarian diets. Thus, it was shown that mortality from ischemic heart disease was 30% lower among vegetarian men and 20% lower among vegetarian women than in non-vegetarians (American Dietetic Association and Dietitians of Canada (2003); Key et al. (1999). Necessary nutrients, proteins, and amino acids for the body's sustenance can be found in vegetables, grains, nuts, soymilk, eggs and dairy. Also, vegetarian diets give lower levels of saturated fat, cholesterol and animal protein, and higher levels of carbohydrates, fibre, magnesium, folate, and antioxidants such as vitamin C and E and phytochemical (Fraser and Beeson, 1999).

Vegetarians have lower body mass index (Appleby et al., 1998) and lower levels of cholesterol, lower blood pressure, and less incidence of heart disease, hypertension, type 2 diabetes, renal disease, metabolic syndrome (Rizzo et al., 2011). The habit of non-lean red meat, in particular, has been considered to be directly associated with increased risk of cancers of the esophagus, liver, colon, and the lungs (Cross et al., 2007). Other studies have shown no significant differences between vegetarians and non-vegetarians in mortality from cerebrovascular disease, stomach cancer, colorectal cancer, breast cancer or prostate cancer (Key et al., 1999). A 2010 study compared a group of vegetarian and meat-eating Seventh Day Adventists and showed that vegetarians scored lower on depression tests and had better mood profiles (Beezhold et al., 2010). However, vegetarians are more likely to be deficient in vitamin B12, leading to increased incidence of osteoporosis and depression (Johnston and Sabate, 1999).

The 2010 version of *Dietary Guidelines for Americans*, a report issued by the U.S. Department of Agriculture and the U.S. Department of Health and Human

Services every five year states: In prospective studies of adults, compared to non-vegetarian eating patterns, vegetarian-style eating patterns have been associated with improved health outcomes lower levels of obesity, a reduced risk of cardiovascular disease, and lower total mortality. Several clinical trials have documented that vegetarian eating patterns lower blood pressure.

On average, vegetarians consume a lower proportion of calories from fat (particularly saturated fatty acids); fewer overall calories; and more fiber, potassium, and vitamin C than do non-vegetarians. Vegetarians generally have a lower body mass index. These characteristics and other lifestyle factors associated with a vegetarian diet may contribute to the positive health outcomes that have been identified among vegetarians (Dietary Guideline, 2011).

In Vietnamese context, the vegetarians are mainly Buddhist. There are two main ways to practice: Theravadas in general eat meat. If Buddhist monks "see, hear or know" a living animal was killed specifically for them to eat, they must refuse it or else incur an offense. However, this does not include eating meat which was given as alms or commercially purchased. In Mahayana Buddhist, Buddha instructs his followers to avoid meat and just eat food derived from plants. Some preliminary studies on this field reported lower plasma total protein, anemia, and higher glucose concentrations, disorders of lipid metabolism (especially hypertriglyceridemia) and hypertension in comparison to non-vegetarian people (Thuy N.H. and et al., 2005; Hoang T.T.H. and et al., 2006).

#### ***1.5.5. Some traits of vegetarian cuisine in Thua Thien Hue Province***

Thua Thien Hue is the land of Buddhist structures, with more than 400 pagodas and 230 Buddhist temples and almost two third of population is Buddhists. Hue vegetarian food was first developed in the reign of the "Buddhist Lord" Nguyen Phuc Nguyen (1563 - 1635) and has become a cultural character of this region. As Buddhist thoughts and cultures penetrated into Vietnam via three main social classes including royal, noble and civilian class, Hue vegetarian food is also divided into 3 categories that involve royal, noble and civilian vegetarian food. Vegetarian meals of common people are really simple and easy to prepare. Regarding noble class and royal class, obviously their food cannot be plain and simple so the cooks have to make higher and more original and sophisticated dishes.

Among common people, almost all families who follow Buddhism or Buddhist coreligionists keep the tradition to eat vegetarian meals twice a lunar month, once on

the fifteen and the other time on the first; many of the elderly pledge to keep 10 days of vegetarianism per month while many other people commit to follow a permanent vegetarian diet. Local people in Hue have the tradition to follow Buddhism. Thus, whenever there are anniversaries of deaths for parents or grand-parents, people usually worship and eat vegetarian food to pray for the peaceful salvation of the spirit.

In Buddhist families who keep a permanent vegetarian diet, these meals often include simple food such as dishes made from soya curd, vegetables and beans processed with peanut oil and soy sauce bought in pagodas.

On common days in pagodas, the meals are even simpler with just soya curd, melons, vegetables and sesame and salt. However, if you go to pagodas at Buddhist festivals, you can encounter great vegetarian parties with a lot of dishes created by the harmonious combination of vegetables, beans, vegetables and fruits processed with vegetable oil and fresh vegetables made from star fruits, figs... all of which form a spectacular and attractive picture.

Almost all pagodas have lots of monthly death anniversaries: for monks and nuns in pagoda, for Buddhists who took refuge and got worshiped in pagoda... In each of such occasion, there are often many Buddhists coming to help and join the vegetarian meals. A Buddhist can invite some friends to visit and enjoy the meals. Even visitors from all over the world can be a part of it. These vegetarian meals of pagodas, though quite frugal with just simple dishes, can provide special tastes thanks to the peaceful religious atmosphere around.

At present, in Hue city, vegetarianism is not only practiced in pagodas but widely spread into all social classes. In the past more than 10 years, there have been more and more vegetarian restaurants open because of the increasing numbers of vegetarians, many of whom are visitors to Hue. "Savoring" dishes is a real "revolution" in processing vegetarian food in Hue (Luc, 2008)

## 2. RATIONALE AND OBJECTIVES

In recent years, developing countries including Vietnam have suffered from a double - disease burden when communicable diseases are still common and the prevalence of non-communicable diseases (NCDs) increases rapidly. Cardiovascular disease, metabolic syndrome and cancer now receive much concern of both government and community. Also, the health care strategy has shifted from treatment to prevention in most of the developing countries to meet the current situation of community health's problems. By this trend, healthy nutrition and life style are supported to be practiced popularly.

Among many different kind of diets, the vegetarian diet has quickly found supporters in Western countries when it was shown that such a diet is associated with better health and may prevent diseases (eg. cardiovascular and metabolic diseases and even cancer) (Anderson et al., 1999; Barasi and Robinson, 1999; Duncan and Bergman, 1999; Key et al., 1999; Fraser and Beeson, 1999).

In many Asian countries, vegetarianism originated from Buddhist principles with some variability in the diet composition and may result in a deficiency of some minerals and nutrients (Alexander et al., 1994; Rao, 1999; Refsum, 2001).

In Vietnam, like in other Asian countries most vegetarians come from the Buddhist religion. It is estimated that the country has about 45 million Buddhists (approximately 50 % of the total population) and 44 495 Buddhist monks and nuns (Report of Vietnamese Buddhist church, 2008). Some preliminary findings on Buddhist Monks and Nuns showed that the vegetarian diet is associated with lower plasma total protein, anemia, and higher glucose concentrations, disorders of lipid metabolism (especially hypertriglyceridemia) and hypertension in comparison to non-vegetarian people (Thuy N.H. and et al., 2005; Hoang T.T.H. and et al., 2006). Similarly, it was also shown that in India, vegetarianism is not associated with greater health. Together, these findings seem to contradict the findings from studies performed in Western countries. It is essential to better understand the impact of a vegetarian diet on human health and its relation to metabolic syndrome and cardiovascular diseases – the two most common non-communicable diseases. This will not only fill a gap in the global database but will also allow to state recommendations for the Buddhist and the non-Buddhist community. Therefore, our research was conducted to investigate the following objectives:

1. *Investigate some biological indices in a vegetarian population in Vietnam*
2. *Identify the prevalence of metabolic syndrome and metabolic syndrome risk factors in a vegetarian population*
3. *Characterize the composition of the vegetarian diet as it is practiced in Vietnam*

### **3. METHODS**

#### **3.1. Study area:**

Thua Thien Hue province in the Central of Vietnam is selected for this study. This place can be considered as a vegetarianism center of Vietnam. In this province, there are nearly 1 million Buddhist (> 90% total population) and over 2000 Buddhist monks and nuns who have been practicing vegetarian diet for a long time.

#### **Some figures of study area:**

Thua Thien Hue is recognized as old capital of Vietnam, the city of festival and tourism. Located in the Central Region of Viet Nam at the latitude 16-1608 North and longitude 10708-10802 East, Thua Thien Hue is bordered on the north by Quang Tri Province, on the south by Da Nang City, on the west by the Truong Son Mountain Range & Laos PDR, and on the east by East Sea.

The province constitutes 5,009 km<sup>2</sup> in total area and is eighty-eight km in circumference along its borders, with 128km-length coast, 22.000 ha of lagoon, more than 200.000 ha of forest, and more than one hundred sites of mineral deposits.

In Thua Thien Hue, nine administrative units is divided including the major city of Hue, six districts in the plains area and two districts in the mountainous areas. The province has a population of nearly 1 million people.

Thua Thien - Hue is cultural heritage of ancient Capital Hue in Vietnam... The ancient capital where is preserving a huge material cultural treasure with an ancient historical place complex. In addition, there are thousands of pagodas which have unique national architecture and non-material cultural treasure with kinds of festivals, religions, traditional and popular festivals. Moreover, it also is famous place for its interesting natural landscapes.

Thua Thien-Hue province has an important strategic position, is the intersection, located on the North-South transport axis and the axis of the East-West corridor linking Thailand - Laos - Cambodia - Vietnam over the road. Chan May port is one of the main gateway to East Sea. Government strategic plan is developed Thua Thien Hue to become a center of tourism, high –technique education & health facilities (Report, 2017).

**3.2. Study population:** The participants will be Vietnamese vegetarians  $\geq 30$  years of age and practicing a pure vegetarian diet for at least 5 years. Based on these requirements, the Buddhist Monks and Nuns and who are living in pagodas within Thua Thien Hue province will be a good selection.

To perform proper comparisons and to obtain reliable results, a control group will be formed from neighboring non-vegetarians with the matching criteria: living in the neighboring area, similarities on age and sex.

We exclude the participants who have medical history of cardiovascular diseases, mental disorders or do not agree to participate in the study.

**3.3. Sampling:** Based on the study inclusion criteria and the fact that Buddhist Monks and Nuns population is quite young, therefore total population sampling were used in this study.

The name list of all Buddhist Monks and Nuns was provided by Thua Thien Hue Buddhist Church with about 300 appropriate subjects. We re-checked and eliminated all deceased subjects and those who have moved out of the province as well as persons not willing or unable to participate in our study. Finally, we got the sample of 183 study subjects.

Moreover, the control group was selected in neighboring area with 181 subjects. In addition, 75 vegetarians were invited to do food questionnaire. After reviewing, the number of study group for food questionnaire was 51 subjects.

**3.4. Data collection:** this research was a cross-sectional analysis to explore the prevalence of metabolic syndrome in Buddhist vegetarians and to describe their current vegetarian diet. All data were collected from the study groups: Vegetarian Buddhist Monks and Nuns and non-vegetarian neighbors. The variables included in the analysis are: age, gender, vegetarian diet, blood pressure, waist circumference, fasting lipids (total cholesterol, triglycerides, HDL-cholesterol, LDL-cholesterol) and fasting glucose. The study personnel to collect the data included medical and nursing students and medical technicians from Hue University of Medical and Pharmacy.

**3.5. Variables:** The variables included:

- + The variables about demographic characteristics
- + The variables about life style, health history,
- + The variables of current health status

ON	Variables	Definition	Classification	Collecting methods
<b>A. Demographic variables</b>				
1	Age	Calculate age by western calendar, to subtract birthage	Discrete var.	Interview

ON	Variables	Definition	Classification	Collecting methods
		of participants by 2014		
2	Gender	Is male or female	Binary var.	Interview
3	Occupation	Is current job of participants	Nominal var.	Interview
4	Educational background	Is the highest educational level that participants completed	Ordinal var.	Interview
5	Marriage status	Is single/ married/ divorce/ widower	Nominal var.	Interview
<b>B. Variables about Health history</b>				
1	Smoking status	Is the smoking status of participants include: (daily, sometimes, smoking history, no smoking)	Ordinal var.	Interview
2	What kind of cigarette	Is the kind of cigarette that participants smoke daily	Nominal var.	Interview
3	Number of cigarette	The number of cigarette smoked daily of participants	Discrete var.	Interview
4	Time of smoking cessation	Is the time of giving smoking (by year)	Discrete var.	Interview
5	Alcohol drinking status	Is drinking status	Binary var.	Interview
6	Kind of alcohol	Is kind of alcohol that participants drink	Nominal var.	Interview
7	Amount of alcohol drinking	Is amount of alcohol drinking that participants drink per day or week	Discrete var.	Interview
8	Sport playing	Is the participating status on sport of participants	Binary var.	Interview
9	Kind of Sport	What kind of sport that participants are playing	Nominal var.	Interview

<b>ON</b>	<b>Variables</b>	<b>Definition</b>	<b>Classification</b>	<b>Collecting methods</b>
10	Level of sport playing	Is the frequent level of participant on sport	Discrete var.	Interview
11	Physical activity on working	Is the frequent of movement on working of participants	Binary var.	Interview
12	Time of physical activity on working	Is the length of time for movement of participant	Discrete var.	Interview
13	History of Cardiovascular diseases	Acquired cardiovascular diseases of participants	Nominal var.	Interview
14	History of respiratory diseases	Acquired respiratory diseases of participants	Nominal var.	Interview
15	History of GI-Urologic diseases	Acquired GI-Urologic disease of participants	Nominal var.	Interview
16	History of endocrinologic diseases	Acquired endocrinologic diseases of participants	Nominal var.	Interview
17	Cancer	Acquired cancer of participants	Discrete var.	Interview
18	History of acute diseases	Is aquired acute diseases within two weeks of participants	Binary var.	Interview
20	History of surgical operation	Is kind of surgical operation that participant already taken	Nominal var.	Interview
21	Health insurance status	is the status of participant own health insurance or not	Binary var.	Interview



ON	Variables	Definition	Classification	Collecting methods
<b>C. Variables about current health status</b>				
1	Height	Is length from head to heel of participants (cm)	Discrete	Measure
2	Weight	Is body weight of participants (kg)	Discrete	Measure
3	Pulse	Is the incidence of pulse per minute	Discrete	Count
2	Blood pressure	Systolic and diastolic pressure of participants (mmHg)	Discrete	Measure
3	Waist circumference	Is abdominal perimeter calculated bypassing umbilicus (cm)	Discrete	Measure
4	Hip circumference	Is both perimeter (cm)	Discrete	Measure
5	BMI	Calculate by weight divided by height squared ( $\text{kg}/\text{cm}^2$ )	Continuously var.	Calculate
6	WHR	Ratio of waist circumference over hip circumference	Continuously var.	Calculate
7	Fasting glucose	Is the fasting glucose	Continuously var.	Measure
8	Total-Chol	Is total cholesterol (mg/dL)	Continuously var.	Measure
9	HDL-C	Is high density cholesterol (mg/dL)	Continuously var.	Measure
10	TG	Is Triglycerid concentration of participants (mg/dL)	Continuously var.	Measure

ON	Variables	Definition	Classification	Collecting methods
11	LDL-C	Is low density cholesterol of participants ( mg/ dL)	Continuously var.	Measure

### 3.6. Instruments

A questionnaire was designed to collect the required information of each participant through an interview, which was followed by a physical exam and a fasting blood sample. The interview was performed by the study personnel while blood sampling was performed by the medical technicians or nurses. The blood test was analyzed at Laboratories of Hue University of Medicine and Pharmacy.

#### Measure procedures:

**Height (cm):** Measured by a graduated vertical line metric, checked by the tailor's nylon fabric meter.

Measurement: The object to be measured is not wearing a hat, not wearing shoes.

Guide the right subjects:

Head straight, the occipital bone touches the ruler, does not tilt to the side, does not bend over or tilt back. Be careful not to let your hair knot or tie your hair over your head.

Two shoulder blades touching the ruler, two hands down, the knee is straight, the feet are closed together, the two heels measure the ruler.

The vertical axis of the body coincides with the axis of the ruler.

Place the scale at the center of the head of the object and perpendicular to the ruler, read the height at the intersection between the bottom edge of the ruler and the ruler.

The results are in centimeters, the height measurement is accurate to 1/10 cm (Nutrition Institute, 2011).

Height of study and control group will be compared with the value of Standard weight of Vietnamese people.

**Table 3.1:** Standard Height of Vietnamese people

Age	Male	Female
30-39	162.75 ± 4.98	152.56 ± 4.16
40-49	161.93 ± 4.77	151.92 ± 4.46
50-59	159.30 ± 4.90	150.18 ± 4.66
≥ 60	157.72 ± 4.82	147.71 ± 5.08

*Source: Biomedical indices of normal Vietnamese in 1990s- 20<sup>th</sup> century (Ministry of Health, 2004)*

**Weight (kg):** Measured by electronic scales (Nhon Hoa scale) was calibrated with other balances, put balance in equilibrium position.

Measurement: Requires subjects to remove shoes, heavy clothes, hats and other weight objects. Guide the right subjects:

Stand lightly on the weight, the legs are placed in the V-shape so that the center of gravity falls to the center of the scale, the tip of the foot towards the face, not cover the face. Do not bend or stand upright. When the clock is stable, read the result. When reading the results, the eyes should be perpendicular to the face, not to be seen.

Weights up to 1/10 kg. Before each weighting, make sure the needle is in the correct position (Pham V.L. , 2012).

Weight of study and control group will be compared with the value of Standard weight of Vietnamese people (published in 2003)

**Table 3.2:** Standard Weight of Vietnamese people

Age	Male	Female
30-39	53.15 ± 5.53	45.98 ±4.97
40-49	53.74 ± 6.64	46.37 ± 5.32
50-59	50.22 ± 5.41	43.96 ±4.69
≥ 60	48.53 ± 5.26	42.16 ±4.50

*Source: Biomedical indices of normal Vietnamese in 1990s- 20<sup>th</sup> century (Ministry of Health, 2004)*

**BMI:** BMI was calculated by following formula:

$$\text{BMI} = \text{Weight (kg)} / (\text{Height})^2 \text{ (m)}$$

BMI classification followed the guidelines of IDI & WPRO 2000:

BMI: < 18,5 : underweight

- BMI: 18,5 - 22,9 : Normal
- BMI: 23,00 : Overweight
- BMI: 23,00 - 24,9 : Pre-obesity
- BMI: 25,00 - 29,9 : Obesity I
- BMI: 30,00 - 39,9 : Obesity II
- BMI: > 40,00 : Obesity III

Average BMI of study and control group will be compared with the value of Standard weight of Vietnamese people (published in 2003)

**Table 3.3:** Standard BMI of Vietnamese people

Age	Male	Female
30-39	20.11 ± 1.85	19.76 ± 1.93
40-49	20.51 ± 2.24	20.08 ± 1.15
50-59	19.89 ± 1.80	19.54 ± 1.96
≥ 60	19.55 ± 1.73	19.36 ± 1.89

Source: Biomedical indices of normal Vietnamese in 1990s- 20<sup>th</sup> century (Ministry of Health, 2004)

**\*Waist circumference** will be measured mid-way between the 10<sup>th</sup> rib and the iliac crest with subject wearing only underwear using a non- elastic flexible tape (Palinski-Wade).

**Measure:** The measurement point is the point between the distance from the lowest point of the ribs to the front of the capillary. The object standing upright with two legs, the investigator standing tilted sideways in perpendicular direction, using a tape measure across the abdominal measurement point and measuring at the normal exhalation of the object, reading the measurement to mm.

**Hip circumference:** Measurement across the two lateral femurs, ensuring that the measurement is horizontal, reading the measurements to mm ...

**\*Blood pressure:** will be measured by procedure guidelines in the textbook of Nursing Faculty, Hue UMP using the ALRK2 sphygmomanometer (Pham V.L. , 2012).

Blood pressure classification was based on JNC VII criteria:

- Normal: <120 mmHg và <80 mmHg
- Pre-hypertension: 120-129 mmHg and / or 80-90 mmHg
- Hypertension I: 140-159 mmHg and / or 90-99 mmHg
- Hypertension II: ≥ 160 mmHg and/ or ≥ 100 mmHg

**\*Blood sample** was collected to measure fasting lipids (Total- Chol, TG, HDL-C LDL-C) and fasting glucose at Biochemical laboratory of Hue UMP (Hue University of Medicine and Pharmacy).

+ Total –Cholesterol was measured by CHOP-PAD with kit from Hycel Diagnostic.

+TG was measured by GPO - PAP (glycerol phosphate oxidase Phenazon Amino peroxidase) methods with kit from Hycel Diagnostic.

+ HDL-C was measured by CHOD - PAP methods with kit from Hycel Diagnostic.

+ LDL- C was measured by fomula:  $LDL-C -C = CT- ( HDL-C + TG/2.2)$

These parameters are measured in autonomy biochemical analysis machine LISA 200 of Hycel Diagnostic (France).

+ Fasting glucose was measured by color comparison method using enzyme glucose oxidase.

All tests were shown by unit of mmol/l and was converted to mg/dL by the guidelines of Vietnam Association of Cardiology (2010) and Diabetes care (2012) (Phuoc D.V and et al., 2010; The Global Diabetes Community):

Fasting glucose: mg/dl= 18x mmol/l

Total –Chol: mg/dl = 38,46 x mmol/l

TG: mg/dl= 86,96 x mmol/l

HDL-C: mg/dl = 38,89 x mmol/l

LDL-C: mg/dl= 38,80 x mmol/l

**Criteria for the diagnosis of the metabolic syndrome** (the definition of the Consensus Statement of IDF, NHLBI, AHA, WHF, IAS, IASO 2009 will be used with specific thresholds waist circumference for Asians)

Risk factor		Defining level
Abdominal obesity	Men	Waist circumference >90 cm
	Women	Waist circumference >80 cm
Triglycerides		≥150 mg/dL
HDL cholesterol	Men	<40 mg
	Women	<50 mg
Blood pressure		≥130/ 85 mmHg
Fasting glucose		≥100 mg/dL

***\*Participants was diagnosed as Metabolic syndrome when having 3 risk***

### **factors or more.**

\*A standardized questionnaire to describe the amount and composition of food used in 24 hours for Monday and Saturday (Sample from National Nutrition Institution of Vietnam) will be used and analyzed with the consultancy from nutritional experts. All food describing data was analysed by Software Eiyokun (Public Health).

\*Statistic software: R and Stata.

### **3.7. Statistical analysis:**

The data was measured as means  $\pm$  standard deviations (for variable with normal distribution) and mean  $\pm$  SE (for variable with non-normal distribution)

The t- test, Mann-Whitney, ANOVA, Kruskal Wallis, chi-square tests were used for comparison characteristic, MeS components, risk factors.

Partial correlation and Pearson correlation was used to seek the relationship between the vegetarian diet and parameters of metabolic syndrome.

Direct age standardization also was used to estimate prevalence of MS and MS components using the Vietnamese population census 2009 as reference population.

A P-value of less than 0.05 will be regarded as statistically significant. Using quantile regression was to identify *p for trend* among MS risk number.

Selecting appropriate models was used the Bayesian model average (BMA). All variables were included in initial selection model. Variables with less important had small weight and removed from selection models. Five best models was indicated. Finally, we chose the best model with eligible variables.

The multivariate logistic regression model was used to predict risk factor contributing to the increasing of MeS risk, which relied on Bayesian model average (BMA) selection.

Statistical procedure was performed using R and STATA 13.0 software.

### **3.8. Time of study: 6/2013-12/2015.**

### **3.9. Ethical considerations**

The research was submitted to the Science Committee of Hue University of Medicine and Pharmacy to have the permission for implementing. Also, a letter describing the details of the project was sent to Thua Thien Hue Buddhist Church. The answer to this letter indicates that the Church will agree to participate and will support the project. All participants will give written informed consent before any study procedure will be performed. A feedback including recommendations about their health assessment will be sent back to the participants as well as they can receive a report of the research findings whenever they want.

## 4. RESULTS

### 4.1. Demographic characteristics

#### 4.1.1. Gender

**Table 4.1: Gender Distribution**

Gender	Vegetarian		Non- Vegetarian		Total
	N	%	N	%	
Male	29	15.84	53	29.28	82
Female	154	84.16	128	70.72	282
<b>Total</b>	<b>183</b>	<b>100</b>	<b>181</b>	<b>100</b>	<b>364</b>

There were considerably more females in both the vegetarian group (84.16%) and the non-vegetarian group (70.72%).

#### 4.1.2. Age

Average age (in years):

Vegetarian group: Male: 56.48±15.41; Female: 58.75±16.02

Non- Vegetarian group: Male: 57.47±13.84; Female: 51.09±14.50

Max: Vegetarian group: Male: 78, Female: 97;

Non- Vegetarian group: Male: 84; Female: 85;

Min: Vegetarian group: Male: 31; Female: 30;

Non- Vegetarian group: Male: 30; Female: 30

**Table 4.2: Age group distribution**

Age group (years)	Vegetarian		Non- Vegetarian		Total
	N	%	N	%	
30-39	30	16.39	38	21.01	68
40-49	23	12.57	40	22.10	63
50-59	35	19.13	52	28.72	87
≥ 60	95	51.91	51	28.17	146
<b>Total</b>	<b>183</b>	<b>100</b>	<b>181</b>	<b>100</b>	<b>364</b>

Age groups were evenly distributed and there was no difference in age between the vegetarian and the non- vegetarian group ( $p>0.05$ )

#### 4.1.3. Occupation

**Table 4.3: Occupational Distribution**

Occupation	Vegetarian		Non- Vegetarian	
	N	%	N	%
Officer	0	0	50	27.62
Worker	0	0	10	5.55
Farmer	0	0	22	12.15
Trader	0	0	27	14.91
Monk/nuns	183	100	0	0
Housewife	0	0	38	20.99
Others	0	0	34	18.78
<b>Total</b>	<b>183</b>	<b>100</b>	<b>181</b>	<b>100</b>

All of vegetarian group were Buddhist Monks and Nuns. In the non-vegetarian group the most common occupations were officer (27.62 %), housewife (20.99%) and trader (14.91%).

#### 4.1.4. Educational background

**Table 4.4: Distribution of educational background**

Educational background	Vegetarian		Non- Vegetarian		Total
	N	%	N	%	
Illiterate	2	1.10	13	7.18	15
Primary level	49	26.78	49	27.07	98
Secondary level	43	23.50	50	27.62	93
High school level	26	14.20	34	18.78	60
College/ University level	55	30.05	26	14.36	81
Graduate level	8	4.37	9	4.99	17
<b>Total</b>	<b>183</b>	<b>100</b>	<b>181</b>	<b>100</b>	<b>364</b>

Most of participants were educated at least primary level. In the vegetarian group 30.05 % of the participants obtained College / University level, which is higher than in the non-vegetarian group (14.36%). 1.1 % (vegetarian group) and 7.18 % (non-vegetarian group) of participants were illiterate.



#### 4.1.5. Lifestyle

**Table 4.5: Distribution of lifestyle**

Life style		Vegetarian		Non- Vegetarian		P
		N	%	N	%	
Smoking	Yes	15	8.20	41	22.65	<0.05
	No	168	91.80	140	77.55	
	Total	183	100	181	100	
Alcohol use	Yes	4	2.19	32	17.68	<0.05
	No	179	97.81	149	82.32	
	Total	183	100	181	100	
Physical activities	Yes	174	95.08	178	98.34	>0.05
	No	9	4.92	3	1.66	
	Total	183	100	181	100	

The percentage of smoking and alcohol use was higher in the non-vegetarian group than in the vegetarian group (smoking: 22.65% vs 8.20% alcohol use: 17.68 % vs 2.19%) with  $p < 0.05$

95.08% in vegetarian group and 98.34% in non-vegetarian group are active persons with adequate physical activities.

#### 4.1.6. Health insurance coverage

**Table 4.6: Distribution of Health Insurance coverage**

Health Insurance	Vegetarian		Non- Vegetarian		Total
	N	%	N	%	
Yes	81	44.27	140	77.35	221
No	102	55.73	41	22.65	143
<b>Total</b>	<b>183</b>	<b>100</b>	<b>181</b>	<b>100</b>	<b>364</b>

Most of participants in non-vegetarian were covered by health insurance with 77.35 % higher than in Vegetarian-group (44.27 %) with  $p > 0.05$ .

#### 4.1.7. Marriage status

**Table 4.7: Distribution of Marriage status**

Marriage status	Vegetarian		Non- Vegetarian		Total
	N	%	N	%	
Single	<b>109</b>	<b>59.56</b>	5	2.77	114
Married	68	37.16	<b>166</b>	<b>91.71</b>	234
Divorce/ Widow	6	3.28	10	5.52	16
<b>Total</b>	<b>183</b>	<b>100</b>	<b>181</b>	<b>100</b>	<b>364</b>

In vegetarians, single status was dominant (59.56%) while in non-vegetarians, the married status was dominant (91.71%). The percentage of divorce was quite low in both the vegetarian and the non-vegetarian group with 3.28% and 5.52%, respectively.

#### 4.2. Some biomedical indices of study and control group

##### 4.2.1. Height:

**Table 4.8: Height distribution**

Height (cm)	Vegetarian		Non- Vegetarian		P
	Male	Female	Male	Female	
Average	161.29 ± 6.69	149.61 ± 6.58	160.98 ± 7.48	152.05 ± 5.82	(male) > 0.05 (female) < 0.05
Max	175	167.5	176	167.5	
Min	148	133	143.5	134	

The average height of male wasn't different between vegetarian and non-vegetarian group but female was.

The maximum height in males was 175 cm in the vegetarian group and 176 cm in the non-vegetarian group while the minimum height was 148 cm and 143.5 cm, respectively.

The maximum height in females was 167.5 cm in both the vegetarian and the non-vegetarian group while the minimum heights were 133 cm and 134 cm, respectively.

**Table 4.9: Height distribution by age**

Average height	Vegetarian		Non- Vegetarian		VNese standardized height (1990s)	
	Male	Female	Male	Female	Male	Female
30-39	160.9 ± 4.70	151.84 ± 3.70	167.25 ± 8.06	154.12 ± 5.60	162.75 ± 4.98	152.56 ± 4.16
40-49	166.50 ± 7.47	150.29 ± 5.34	163.95 ± 7.49	152.05 ± 4.29	161.93 ± 4.77	151.92 ± 4.46
50-59	158.50 ± 7.33	152.39 ± 6.31	163.94 ± 6.22	153.79 ± 4.87	159.30 ± 4.90	150.18 ± 4.66
≥ 60	160.43 ± 6.56	147.68 ± 7.06	155.83 ± 5.36	147.68 ± 6.22	157.72 ± 4.82	147.71 ± 5.08

According to distribution of height by group age, at 30-39 yrs old, the height of non-vegetarian group was higher than standardized height of Vietnamese people and vegetarian group.

At 40-49 and ≥ 60 years old group, the height of male vegetarian group was higher than in non-vegetarian and standardized group while height of female was lower.

At 50-59 years, the height of male in vegetarian group was lower than in non-vegetarian and standardized group while female was higher than in standardized group but lower than in non-vegetarian group.

#### **4.2.2. Weight**

**Table 4.10: Weight distribution**

Weight (kg)	Vegetarian		Non- Vegetarian		P
	Male	Female	Male	Female	
Average	56.97 ± 8.04	48.89 ± 7.38	57.56 ± 9.93	50.47 ± 7.79	> 0.05
Max	70	79	85	70	
Min	42	35	42	32	

The average weight of males and females wasn't different between the vegetarian and the non- vegetarian group (p>0.05).

The maximum weight in male was 70 kg in the vegetarian group and 85 kg in the non-vegetarian group while the minimum weight was 42 kg in both groups.

The maximum weight in female was 79kg in the vegetarian group and 70 kg in the non-vegetarian group while the minimum weights were 35kg and 32 kg, respectively.

**Table 4.11: Weight distribution by age**

Average Weight	Vegetarian		Non-Vegetarian		VNese standardized weight (1990s)	
	Male	Female	Male	Female	Male	Female
30-39	54.40 ± 8.38	48.42 ± 5.00	72.00 ± 14.72	52.50 ± 6.95	53.15 ± 5.53	45.98 ± 4.97
40-49	57.00 ± 9.75	47.70 ± 6.41	60.91 ± 7.27	50.38 ± 6.34	53.74 ± 6.64	46.37 ± 5.32
50-59	60.00 ± 9.13	50.65 ± 7.48	60.12 ± 7.73	53.16 ± 7.32	50.22 ± 5.41	43.96 ± 4.69
≥ 60	57.00 ± 7.70	48.63 ± 8.13	50.98 ± 7.10	45.17 ± 8.13	48.53 ± 5.26	42.16 ± 4.50

According to distribution of weight by group age, the weight of both the vegetarian and the non-vegetarian group were higher than the standardized weights of Vietnamese people.

At group age 30-39, 40-49 and 50-59 years old, the weight of the non-vegetarian group was higher than that of the vegetarian group and the standardized weight of Vietnamese people.

At ≥ 60 years old group, the weight of the vegetarian group was the highest.

#### 4.2.3. Body Mass Index

**Table 4.12: Distribution of Body Mass Index**

BMI (kg/m <sup>2</sup> )	Vegetarian		Non-Vegetarian		P
	Male	Female	Male	Female	
Average	21.86 ± 2.48	21.81 ± 2.70	22.11 ± 2.75	21.80 ± 2.94	p > 0.05
Max	25.71	29.37	28.39	28.57	
Min	17.30	15.35	17.15	13.49	

The average Body Mass Index (BMI) in males and females wasn't different between the vegetarian and the non-vegetarian groups ( $p>0.05$ ).

The maximum BMI in males was 25.71 kg/m<sup>2</sup> in the vegetarian group and 28.39 kg/m<sup>2</sup> in the non-vegetarian group while the minimum BMI was 17.30 kg/m<sup>2</sup> and 17.15 kg/m<sup>2</sup>, respectively.

The maximum BMI in females was 29.37 kg/m<sup>2</sup> in the vegetarian group and 28.57 kg/m<sup>2</sup> in the non-vegetarian group while the minimum BMI was 15.35 kg/m<sup>2</sup> and 13.49 kg/m<sup>2</sup>, respectively.

**Table 4.13: BMI distribution by age**

Average BMI by age group	Vegetarian		Non-Vegetarian		VNese standardized BMI (1990s)	
	Male	Female	Male	Female	Male	Female
30-39	20.91 ± 2.18	21.00 ± 2.05	25.52 ± 3.15	22.08 ± 2.44	20.11 ± 1.85	19.76 ± 1.93
40-49	20.58 ± 3.49	21.17 ± 2.57	22.67 ± 2.34	21.82 ± 2.85	20.51 ± 2.24	20.08 ± 1.15
50-59	23.88 ± 3.07	21.80 ± 2.87	22.36 ± 2.51	22.44 ± 2.57	19.89 ± 1.80	19.54 ± 1.96
≥ 60	22.07 ± 1.83	22.22 ± 2.78	20.97 ± 2.54	20.72 ± 3.69	19.55 ± 1.73	19.36 ± 1.89

According to distribution of weight by age-group, the BMI of both the vegetarian and the non-vegetarian groups were higher than the standardized BMI of Vietnamese people.

At group age 30-39, 40-49 yrs old, the BMI of the non-vegetarian group was higher than that of the vegetarian group and the standardized weight of Vietnamese people.

At group age 50-59 and ≥ 60 years old, the BMI of the vegetarian group was highest one.

**Table 4.14: BMI classification**

BMI (kg/m <sup>2</sup> )	Vegetarian		Non-Vegetarian		P
	N	%	N	%	
Underweight	17	9.29	20	11.05	>0.05
Normal	110	60.10	103	56.91	>0.05
Pre -Obesity	35	19.13	30	16.57	>0.05
Obesity I	21	11.48	28	15.47	>0.05
<b>Total</b>	<b>183</b>	<b>100</b>	<b>181</b>	<b>100</b>	

The percentage of underweight was somewhat higher in the non- vegetarian group (11.05 %) than in the vegetarian group (9.29%).

The percentage of normal BMI was slightly lower in the non- vegetarian group (56.91%) than in the vegetarian group (60.10%).

The percentage of pre-obesity was higher in the vegetarian group (19.13%) than in the non-vegetarian group (16.57%)

The percentage of obesity I in the vegetarian group and the non-vegetarian group was 11.48 % and 15.47 %, respectively.

The differences between both group were not significant with  $p > 0.05$ .

#### 4.2.4. Blood pressure

+ Vegetarian group:  $121.23 \pm 19.12 / 75.30 \pm 9.75$  mm Hg

+ Non-Vegetarian group:  $124.94 \pm 22.96 / 76.10 \pm 11.12$  mmHg

**Table 4.15: Distribution of Blood Pressure**

BP (mmHg)		Vegetarian	Non- Vegetarian	P
Ave.BP	Male	$127.76 \pm 17.66 /$ $81.21 \pm 10.58$	$140.85 \pm 23.01 /$ $82.45 \pm 11.25$	$p < 0.05$
	Female	$120.00 \pm 19.19 /$ $74.19 \pm 9.21$	$118.36 \pm 19.51 /$ $73.48 \pm 9.99$	$p > 0.05$
Max BP	Male	170/100	200/110	
	Female	180/100	190/100	
Min BP	Male	100/60	110/60	
	Female	85/50	80/50	

The average systolic blood pressure of males in the non-vegetarian group ( $140.85 \pm 23.01$ mmHg) was significantly ( $p < 0.05$ ) higher than in the vegetarian group ( $127.76 \pm 17.66$ ) while in females there was no significant difference between the non-vegetarian group ( $118.36 \pm 19.51$ mmHg) and the vegetarian group ( $120.00 \pm 19.19$  mmHg)

There was no difference between the two groups in diastolic blood pressure.

The maximum blood pressure in males were 170/100 mmHg in the vegetarian group and 200/110 mmHg in the non-vegetarian group while the minimum values were 100/60 mmHg and 110/60 mmHg, respectively.

The maximum blood pressure in females were 180/100 mmHg in the vegetarian group and 190/110 mmHg in the non-vegetarian group while the minimum values were 85/50 mmHg in both the vegetarian and the non-vegetarian group.

**Table 4.16.** Distribution of blood pressure by JNC VII classification

Blood pressure	Vegetarian		Non-Vegetarian		P
	N	%	N	%	
Normal	118	64.49	115	63.54	p < 0.05
Pre- hypertension	24	13.11	23	12.71	
Hypertension I	36	19.67	22	12.15	
Hypertension II	5	2.73	21	11.60	
<b>Total</b>	<b>183</b>	<b>100</b>	<b>181</b>	<b>100</b>	

The percentage of normal blood pressure, pre- hypertension and hypertension I were significantly ( $p < 0.05$ ) higher in the vegetarian group than in the non vegetarian group.

The percentage of hypertension II in vegetarian group were lower significantly than in non vegetarian group with  $p < 0.05$ .

#### 4.2.5. Waist Circumference, Hip Circumference and Waist/Hip Ratio

**Table 4.17:** Distribution of Waist Circumference

W.C (cm)		Vegetarian	Non-Vegetarian	P
Average WC	Male	76.52 ± 9.16	81.13 ± 8.57	< 0.05
	Female	75.57 ± 9.85	76.00 ± 8.04	> 0.05
Max W.C	Male	97	104	
	Female	105	97	
Min W.C	Male	60	65	
	Female	55	54	

The average waist circumference in males in the vegetarian group (76.52 ± 9.16 cm) was significantly lower than in the non- vegetarian group (81.13 ± 8.57 cm) with  $p < 0.05$ .

The average waist circumference of females in the vegetarian group (75.57 ± 9.85 cm) was not different from the non- vegetarian group (76.00 ± 8.04 cm) with  $p > 0.05$ .

The maximum waist circumference in males was 97 cm in the vegetarian group and 104 cm in the non-vegetarian group while the minimum values were 60 cm and 65 cm, respectively.

The maximum waist circumference in females was 105cm in the vegetarian group and 97 cm in the non-vegetarian group while the minimum values were 55 cm and 54 cm, respectively.

**Table 4.18: Distribution of Hip Circumference**

H.C (cm)		Vegetarian	Non-Vegetarian	P
Ave.H.C	Male	89.83 ± 5.92	92.83 ± 6.18	< 0.05
	Female	93.62 ± 6.68	90.53 ± 5.72	> 0.05
Max WC	Male	103	108	
	Female	97.4	106	
Min WC	Male	80	80	
	Female	68	78	

The average hip circumference in males in the vegetarian group (89.83 ± 5.92cm ) was significantly lower than in the non- vegetarian group (92.83 ± 6.18 cm) with p<0.05.

The average hip circumference of females in the vegetarian group (93.62 ± 6.68cm) was not different from the non- vegetarian group (90.53±5.72 cm) with p>0.05.

The maximum hip circumference in males was 103 cm in the vegetarian group and 108 cm in the non-vegetarian group while the minimum values were 80 cm in both groups.

The maximum hip circumference in females was 97.4 cm in the vegetarian group and 106 cm in the non-vegetarian group while the minimum values were 68 cm and 78 cm, respectively.

**Table 4.19: Distribution of Waist- Hip Ratio**

WHR (cm)		Vegetarian	Non-Vegetarian	P
Ave.WHR	Male	0.63± 0.07	0.62 ± 0.07	> 0.05
	Female	0.55 ± 0.06	0.55 ± 0.06	> 0.05
Max WHR	Male	0.79	0.81	
	Female	0.80	0.69	
Min WHR	Male	0.53	0.50	
	Female	0.42	0.41	

There was no significant difference in waist–hip ratio between the vegetarian and the non-vegetarian groups in both males and females with p>0.05.

The maximum waist–hip ratio in males was 0.81 in non - vegetarians and 0.79 in vegetarians while the minimum values were 0.50 and 0.53, respectively

The maximum waist–hip ratio in females was 0.69 in the non - vegetarians and 0.80 in the vegetarians while the minimum values were 0.41 and 0.42 , respectively.

#### **4.2.6. Fasting Glucose**

Average glucose: 90.94 ± 22.85 mg/dL

Min: 55.08 mg/dL; Max: 241.56 mg/dL



**Table 4.20.** Distribution of fasting glucose

Fasting glucose (mg/dL)		Vegetarian	Non- Vegetarian	P
Average F.Glucose	Male	98.68 ± 29.01	90.11 ± 22.44	> 0.05
	Female	90.48 ± 24.15	89.05 ± 19.46	> 0.05
	Total	91.78 ± 25.07	90.11 ± 20.38	p>0.05
Max F.Glucose	Male	225.72	184.32	
	Female	241.56	220.14	
Min F.Glucose	Male	71.10	59.58	
	Female	57.24	55.08	

There was no difference in fasting glucose values between the vegetarian and the non-vegetarian groups in both males and females with p>0.05.

The maximum fasting glucose value in males was 225.72 mg/dL in the vegetarian group and 184.32 mg/dL in the non-vegetarian group while the minimum values were 71.10 and 59.58 mg/dL, respectively.

The maximum fasting glucose value in females was 241.56 mg/dL in the vegetarian group and 220.14 in the non-vegetarian group while the minimum values were 57.24 and 55.08 mg/dL, respectively.

**Table 4.21.** Classification fasting glucose by ADA 2013 (Association, 2013)

Fasting glucose	Vegetarian		Non- Vegetarian		P
	N	%	N	%	
Normal	173	94.53	173	95.58	>0.05
Diabetes	10	<b>5.47</b>	8	<b>4.42</b>	>0.05
<b>Total</b>	<b>183</b>	<b>100</b>	<b>181</b>	<b>100</b>	

Based on ADA 2013 criteria, the percentage of diabetes was 4.42 in the non-vegetarian group and 5.47 in the vegetarian group. There was no significant difference in the diabetes rate between the two groups.

#### 4.2.7. Lipid profile

**Table 4.22.** Distribution of lipid profile

Lipid Profile (mg/dL)		Vegetarian	Non- Vegetarian	P
Average Total Cholesterol	Male	154.17 ± 31.84	182.63 ± 32.08	<0.01
	Female	165.23 ± 37.52	183.78 ± 32.81	<0.01
	Total	163.48 ± 36.82	183.44 ± 32.51	<0.01
Average Triglyceride	Male	192.64 ± 215.23	136.64 ± 87.15	> 0.05
	Female	139.72 ± 39.84	108.13 ± 15.77	< 0.01
	Total	148.10 ± 113.40	116.48 ± 67.51	<0.01
Average LDL- Cholesterol	Male	87.21 ± 23.92	106.85 ± 32.24	< 0.01
	Female	96.66 ± 31.51	113.49 ± 27.30	<0.01
	Total	95.16 ± 30.58	111.54 ± 28.90	<0.01
Average HDL- Cholesterol	Male	38.22±13.01	51.28 ±15.00	<0.01
	Female	44.94 ±10.56	50.14 ±11.34	<0.01
	Total	43.87±11.22	50.47±12.49	<0.01

The average Total –Cholesterol, LDL –Cholesterol and HDL- Cholesterol in males and females of the vegetarian group was significantly lower than in the non- vegetarian group with  $p < 0.01$ .

The average Triglyceride in males and females of the vegetarian group was significantly higher than in the non- vegetarian group with  $p < 0.01$ .

**Table 4.23.** Distribution of lipid disorders

Lipid profile		Vegetarian		Non- Vegetarian		p
		N	%	N	%	
Total –Chol	Normal	160	87.43	132	72.93	<0.05
	High	23	12.57	49	27.07	< 0.05
TG	Normal	177	96.72	177	97.79	> 0.05
	High	6	3.28	4	2.21	> 0.05
HDL –Chol	Low	66	36.06	38	20.99	< 0.05
	Normal	105	57.38	109	60.22	< 0.05
	High	12	6.56	34	18.79	< 0.05
LDL-Chol	Normal	164	89.62	140	77.35	< 0.05
	High	19	10.38	41	22.65	< 0.05

Hypercholesterolemia was more common in the non-vegetarian group than in the vegetarian group (27.07% vs. 12.57%;  $p < 0.05$ ). Although hypertriglyceridemia was slightly more common in the vegetarian group than in the non-vegetarian group (3.28% vs 2.21%) but this difference was not significant.

For HDL-Cholesterol, the percentage of low HDL-Cholesterol in the non-vegetarian group (20.99%) was significantly lower than in the vegetarian group (36.06%) with  $p < 0.05$  while the percentage of high HDL-cholesterol (18.79%) was significantly higher than in vegetarian group (6.56%).

The percentage of high LDL- Cholesterol was significantly higher in the non-vegetarian group (22.65%) than in the vegetarian group (10.38%) with  $p < 0.05$

### 4.3. Impact of vegetarian diet to metabolic syndrome

#### 4.3.1. Prevalence of Metabolic syndrome in the vegetarian and the non-vegetarian group

*Table 4.24. Distribution of prevalence of metabolic syndrome and its criteria*

MS & its criteria	All		Non-vegetarian		Vegetarian		p-value
	Prevalence	95%CI	Prevalence	95%CI	Prevalence	95%CI	
MS-Unadjusted	<b>24.73</b>	20.3- 29.2	<b>22.65</b>	16.5-28.8	<b>26.78</b>	20.3-33.3	0.362
<b>MS Age-adjusted</b>	<b>19.0</b>	15.0- 22.9	<b>19.9</b>	14.2- 25.7	<b>15.9</b>	11.0- 20.8	0.811
Male*	25.6	13.7-37.4	32.5	14.0-51.1	25.4	11.4-39.5	0.502
Female*	17.8	13.6- 22.0	19.5	13.0- 25.9	14.3	9.5- 19.1	0.622
<b>Waist circumference*</b>	<b>20.1</b>	15.9-24.3	<b>20.9</b>	14.8-27.1	<b>17.6</b>	12.7-22.6	0.476
Male*	13.4	3.3-23.5	22.9	5.7-40.2	6.1	2.6-14.8	0.371
Female*	22.9	18.2-27.6	24.0	16.7-31.2	19.9	14.1-25.7	0.969
<b>Triglycerides (&gt;150 mg/dL)</b>	<b>22.6</b>	18-27.2	<b>18.6</b>	12.8-24.4	<b>26.2</b>	18.7- 33.7	<b>0.028</b>
Male*	30.3	18-42.6	36.1	17.2-55.0	32.5	17.0 -48.5	0.581

Female*	20.5	15.7-25.4	15.3	9.3-21.3	25.0	16.9-33.1	0.028
<b>HDL-Cholesterol*</b>			<b>39.6</b>				
	<b>55.2</b>	49.4- 61.0	<b>(26.2-53.0)</b>	35.2-50.4	68.0	59.5-76.4	
			42.8				0.000
Male* (<40 mg/dL)	39.6	26.16-53.0	30.7	12.3-49.1	59.3	39.6-79.0	0.001
Female* (<50 mg/dL)	60.5	54.2- 66.8	50.5	41.8- 59.1	70.7	61.7-79.7	0.001
<b>Blood pressure*</b> <b>(≥130/85 mmHg)</b>	<b>29.3</b>	24.9-33.6	34.6	28.5-40.6	23.1	17.5-28.8	0.004
Male*	47.4	35.3-59.6	61.3	42.3-80.3	29.9	20.7-39.2	0.099
Female*	24.0	19.5-28.6	27.2	20.9-33.5	22.4	15.9-28.9	0.139
<b>Fasting glucose</b> <b>* (≥100 mg/dL)</b>	<b>16.0</b>	11.9-20.0	18.0	12.1-23.8	12.6	7.3-17.8	0.616
Male*	21.2	10.8-31.6	23.3	6.7-40.0	19.3	5.7-33.0	0.483
Female*	14.3	10.1-18.6	17.4	10.7-24.0	10.5	5.5-15.4	0.313

\*: Direct age adjustment of the data was done for the Vietnamese population aged ≥30 years in the year 2009

This table describes the prevalence of MeS and the five components defining the MeS, stratified by vegetarian and non-vegetarian group. The age-adjusted prevalence of metabolic syndrome in total population was 19.0%. The age-adjusted prevalence of metabolic syndrome in females was lower than in males (17.8 % vs 25.6%, respectively). The age-adjusted prevalence of metabolic syndrome in the vegetarian group (15.9%) was lower than in the non-vegetarian group (19.9%) but none of these differences was statistically significant.

The metabolic syndrome criteria elevated waist circumference, elevated blood pressure and elevated glucose were more common in the non-vegetarian group while elevated triglycerides and low HDL-cholesterol were more common in the vegetarian group. Thus, despite the fact that the prevalence of metabolic syndrome was not significantly different between vegetarians and non-vegetarians both groups were characterized by different metabolic syndrome components.

**Table 4.25:** *The association of risk factors and metabolic syndrome*

Variables	Overall			Non-vegetarian		Vegetarian	
	crude OR(95% CI)	adj. OR(95% CI)	P(Wald's test)	adj. OR(95% CI)	p-value	adj. OR(95% CI)	p-value
Study group							
Non	1	-	-				
Vegetarian	1.25(0.77-2.01)	1.00 (0.59-1.80)	0.991	-	-	-	
Age (years)			< 0.001				
30–39	1	1		1	-	-	-
40–49	4.58 (1.22-17.29)	4.29 (1.07-17.11)	0.039	4.2 (0.90- 19.9)	0.068	1	-
50–59	9.75 (2.81-33.8)	8.65	0.001	6.6 (1.5-28.9)	0.012	8.34	0.011

		(2.37-31.61)				(1.61-43.06)	
≥ 60	10.95 (3.27-36.6)	12.6 (3.5-45.45)	< 0.001	5.6 (1.2- 26.0)	0.028	15.22 (3.34-69.48)	< 0.001
Overweight/Obesity (BMI(≥23 kg/m <sup>2</sup> ))					< 0.001		
Normal	1	1	< 0.001	1		-	
Overweight	7.08 (0.94-53.35)	7.9 (1.03-60.47)	0.047	5.1 ( 0.5- 52.0)	0.166	1	
Preobesity I	19.71 (2.54-153.29)	23.51 (2.94-188.18)	0.003	8.2 (0.7-96.90)	0.093	5.96 (2.36-15.07)	< 0.001
Preobesity II	62 (7.82-491.41)	72.87 (8.92-595.1)	< 0.001	71.8 (6.3- 811.9)	0.001	6.72 (2.29-19.78)	< 0.001
Physical activity							
No	1			1		1	
Yes	0.65 (0.19-2.2)	1.72 (0.41-7.18)	0.46	0.08 (0.00- 2.0)	0.129	4.89 (0.84-28.67)	
Adjusted R <sup>2</sup>		21.4%		24,1%		22.8%	

Bayesian model average (BMA) selections by group: age, sex, study groups, occupation, insurance, BMI, physical activity, smoking, chronic diseases. Regarding BMA model, the best model including high weighted variables in the highest posterior model probability have been used the final analysis.

#### 4.4. Vegetarian diet describing

##### 4.4.1. General describing on food habits and practice

**Table 4.26.** Distribution of food habits and practice

Food habits and practice		Vegetarian group	
		N	%
Diet time	5 - <10 year	13	25.49
	10-20 years	21	41.18
	>20 years	17	33.33
	Total	51	100
Reason for vegetarian diet	For health	8	15.69
	For Buddhist practice	42	82.35
	For both	1	1.96
	Total	51	100
Place for often eating	Home	50	98.04
	Out	1	1.96
	Total	51	100
Drink when eating	Yes	17	33.33
	No	34	66.67
	Total	51	100
What drinks taken when eating	Mineral water	1	5.88
	Pure water	15	88.24
	Soft drink	1	5.88
	Total	17	100
Rice for cooking food	Vietnamese rice	46	90.20
	Exported rice	1	1.96
	Brown rice	4	7.84
	Total	51	100
Cooking oil	Soya oil	43	84.31
	Sesame oil	1	1.96
	Peanut oil	7	13.73
	Total	51	100



Place for buying food	Supermarket	2	3.92
	Market	32	62.75
	Market + self –planting	14	27.45
	Supermarket + Market	3	5.88
	Total	51	100
Diet guidance	Yes	6	11.76
	No	45	88.24
	Total	51	100
Who guide for diet	Health staff	3	50.00
	Friends	2	30.33
	Media ( TV, newspaper)	1	16.67
	Total	6	100

#### 4.4.2. Food composition

**Table 4.27.** Distribution of food composition related to energy

Food composition	Vegetarian group	Non-Vegetarian group	National recommendation (2000)
	Mean $\pm$ SD	Mean $\pm$ SD	
Energy (kcal/day)	1417 $\pm$ 43.64	1862.16 $\pm$ 65.42	1900-2200 (Males) 1800-2100 (Females)
Protein (g/day)	45.92 $\pm$ 1.50	88.01 $\pm$ 4.01	55-60
Lipid (g/day)	23.12 $\pm$ 1.54	40.26 $\pm$ 2.37	36-48
Carbohydrate	260.91 $\pm$ 8.67	295.88 $\pm$ 133.82	350-375

At the participants of vegetarian diet, the average energy was 1417  $\pm$  43.64 Kcal/ day, protein was 45.92  $\pm$  1.50 g/day, lipid was 23.12  $\pm$  1.54g, carbohydrate was 260.91  $\pm$  8.67 g/ day

At the participants of non- vegetarian diet, the average energy was 1862.16  $\pm$  65.42Kcal/ day, protein was 88.01 $\pm$ 4.01g/day, lipid was 40.26 $\pm$ 2.37g/ day, carbon hydrate was 295.88  $\pm$  133.82g/ day.

**Table 4.28.** *Distribution of food composition related to mineral and vitamins*

Food composition	Vegetarian group	Non-Vegetarian group	National RRecommendation (2000)	
	Mean ± SD	Mean ± SD	Males	Females
Retinol	41.93±9.25	207.34±32.63	-	-
Caroten	3275.95±247.30	4053.42±374.15	-	-
Vitamin B1	0.80±0.04	89.64±57.24	1.2	0.9
Vitamin B2	0.77±0.05	91.76±55.19	1.80	1.30
Vitamin PP	10.86±0.53	17.54±0.85	19.80	14.50
Vitamin C (mg/day)	86.09±6.20	377.24±157.82	75	70
Canxi (mg/day)	453.46±24.65	857.26±98.85	500	500
P	659.07±24.46	1012.53±50.87	-	-
Fe (mg/day)	11.62±0.51	14.61±0.67	11	24

At vegetarian group, values of mineral substances and vitamins were lower significantly than in non-vegetarian group and national recommendation on nutrition.

## **5. DISCUSSION**

### **5.1. Demographic Characteristics**

#### **5.1.1. Gender**

Our study was implemented on 183 vegetarians and 181 non-vegetarians. In our samples, 84.16% of vegetarians and 70.72 % of non-vegetarians were female. This gender distribution was similar to the studies of Thuy N.H. and et al. (2005) and Hoang T.T.H. and et al. (2006).

The reason of high percentage of female and low percentage of male on Vietnamese vegetarianism researches is related to the living style of Buddhist Monks and Nuns. With religious regulation and a quite closed life, it is not easy to access the Buddhist Monks and Nuns, especially the Buddhist Monks.

#### **5.1.2. Age**

In order to assure to see the impacts of metabolic syndrome, we designed to select participants who were 30 years and over and practiced vegetarian diet for at least 5 years. Such criteria of age was our difficulty in sample size calculation and data collection due the the current status of young vegetarian population.

The mean age of the vegetarian group in our study was  $56.48 \pm 15.41$  years in males and  $58.75 \pm 16.02$  years in females. In the non-vegetarian group, the mean age was  $57.47 \pm 13.85$  years in males and  $51.09 \pm 14.50$  years in females. The maximum age of our population was 97 years old for females and 78 years old for males. There was no significant difference in age between the vegetarian and the non vegetarian group.

According to the table 4.2, the age groups were evenly distributed in the non-vegetarian group. 51.59% of participants in the vegetarian group were 60 years and over. However, there was no difference between the vegetarian and the non-vegetarian group with  $p > 0.05$ . The documental records in Buddhist Church of Thua Thien Hue Province showed that nowadays, many Buddhist Monks and Nuns had more opportunities to go abroad for study and religious practice so the staying ones in pagodas are majorly elderly.

#### **5.1.3. Occupation**

In this study, the whole vegetarian group consisted of 183 Buddhist Monks and Nuns. In the non- vegetarian group, there were 27.62% officers, 20.99% housewives and 14.91% traders. Myong et al. (2012) investigated the prevalence of metabolic syndrome among the Korean working population and determined whether the prevalence differed according to occupation, age and gender. The finding showed that manual occupations could be a risk factor for metabolic syndrome.

#### **5.1.4. Educational background:**

Our study shows that, the majority of subjects in the vegetarian group had a high education background. College/ University level was 30.05%, 4.37% in graduate level, however Illiterate was 1.10%.

Thua Thien Hue province is a well-known and an educated area in Central Vietnam. The general education has been good, and the proportion of highly educated subjects has always prevailed in the samples. Besides, Hue University is the regional university of the central region with thousands students every year. Especially, the availability of Buddhist schools is therefore a possible reason to explain the higher college/university education rate. The illiteracy rate in this study mostly relates to the elderly who were 60 years old and over.

#### **5.1.4. Lifestyle:**

In this study, smoking and drinking alcohol rate in the vegetarian group was lower than in the vegetarian group (smoking: 8.20% vs 22.65% alcohol use: 2.19% vs 17.68 % with  $p < 0.05$ ). Futhermore, physical activity is at a high level in both groups with 95.08% in the vegetarian group and 98.34% in the non-vegetarian group. These findings were similar with findings from previous studies. Chang-Claude et al. (2005) revealed that there were low prevalence of smoking and moderate or high level of physical activity in the vegetarian group. Gacek (2010) found that a higher percentage of vegetarians do not drink alcohol and do not smoke cigarettes. Alcohol abstinence was declared by 75% of vegans, 25% of lacto-ovo vegetarians and only 8% of people with traditional model of eating. Tobacco non-smoking was declared by 94% of vegans, 74% of lacto-ovo vegetarians and 67% of traditional eating people.

Futhermore, Alewaeters et al. (2005) analyzed lifestyle in Flemish vegetarians compared with non-vegetarians. The result showed that vegetarians smoked less than non-vegetarians (13.5% compared with 28.5% respectively;  $p < 0.001$ ). The percentage of subjects consuming alcoholic drinks in the two populations was comparable (32.8 in the vegetarian and 35.8 in the reference population;  $p = 0.159$ ). Non vegetarians drank alcohol compared with the vegetarian subjects (70.2% vs. 58.6% respectively;  $p = 0.026$ ).

On other hand, physical activities rate in both group in this study was adequaterate (95.08% in the vegetarian group and 98.34% in the non-vegetarian group). This result contrasts with the result of another study. Alewaeters et al. (2005) showed that more vegetarians were involved in intensive physical activity compared with non vegetarians (36.8% vs. 17.3% respectively;  $p < 0.001$ ). Gacek (2010) found that a higher percentage of vegetarian took up physical activity in their free time.

### **5.1.5. Health insurance coverage:**

Health insurance coverage is high in both non-vegetarian and vegetarian groups (77.90 % in non-vegetarian group, 44.27 % in vegetarian group). According to the Law on Health Insurance (Vietnam, 2014), the health insurance is compulsory for all employees of all type of firms since 2009 and to the self-employed, the dependents and others since 2014. Until now, it still had yet achieved universal health insurance coverage however the rate of health insurance has increased. In 2013, 68% of the total population were covered by the health insurance and the government wanted to reach a coverage level of 80% by 2020 and 100% by 2030 (Rousseau, 2014).

### **5.1.6. Marriage status**

Single status was the highest in vegetarians (59.96%), on the other hand, married status was dominant in non-vegetarians (91.71%). The percentage of divorce was quite low in both the vegetarian and the non-vegetarian group with 3.28% and 5.52%. All of the vegetarians in our study are Buddhist Monks and Nuns, which is the main reason for the dominant single status in the vegetarian group.

## **5.2. Some biomedical indices of study and control group**

Concerning biomedical parameters, height and weight are important anthropometric indices related to nutrition status; body mass index (BMI) has a strong relation to overweight and obesity associated risk for metabolic syndrome. In vegetarians and non vegetarians in this study, there is no significant difference for height, weight and BMI.

However, the height in males of vegetarian group was slightly higher than in non-vegetarians group and within in normal range of Vietnamese people while height of females of the vegetarian group was significantly lower than in females of the non-vegetarian group with  $p < 0.05$ . This may relate to poorer nutrition in female vegetarians than in males. To compare with other studies, our study population had lower values for height, weight and BMI than and Hoang T.T.H. and et al. (2006) but similar to Le N.T. (2000), Phan T.S. and et al. (2001). This may relate to the fact that our study group was mainly middle age and older and had suffered from poor nutrition during the war than the younger populations of Hoang T.T.H. and et al. (2006) and Western population.

Unlike Western vegetarian studies, the median of height, weight and BMI in this study was still within the normal range and tended to be lower than in Western vegetarians (Spencer et al., 2003; Alewaeters et al., 2005; Rizzo et al., 2011). Furthermore, the mean height, weight and BMI in vegetarians in this study was similar to

South Korean vegetarians (Lee and Krawinkel, 2009). Level of height, weight and BMI in Taiwanese vegetarians were reported that was higher than subject in this study (Chen et al., 2008). Baines et al. (2007) analyzed health and well-being of young Australian vegetarians. The finding revealed that vegetarians and semi vegetarians had lower body mass index than non-vegetarians. Chiang et al. (2013) reported that the Taiwanese vegetarian status was associated with lower body mass index, smaller waist circumference.

Moreover, WHR and fasting glucose in vegetarians tended to be higher than in non vegetarians in this study. Unexpectedly, the waist circumference, hip circumference and blood pressure of vegetarians males was significantly lower than non vegetarians males ( $p < 0.05$ ), while there was no significant difference in females. Similarity, Jung et al. (2013) showed that waist-to-hip ratio was higher in the Buddhist priest group. In addition, these values are similar to those reported by Binh et al. (2014). Blood pressure is an important parameter to diagnose metabolic syndrome. In our study, average blood pressure was within normal range in the vegetarian group and non-vegetarian females while it was quite high in non-vegetarian males ( $140.85 \pm 23.01 / 82.45 \pm 11.25$  mmHg). Our normal values were higher than the values reported by Binh et al. (2014) in a middle age group in the North of Vietnam. If the group of vegetarians is compared I non vegetarians, the percentage of normal blood pressure, pre- hypertension and hypertension stage I was significantly higher in the vegetarian group than in the non vegetarian group ( $p < 0.05$ ). But the percentage of hypertension II was significantly lower in the vegetarian group than in the non vegetarian group with  $p < 0.05$ .

On average fasting glucose was  $91.78 \pm 25.07$ mg/dL in vegetarians and  $90.11 \pm 20.38$ mg/dL in non vegetarians. This result is similar to the one reported by Thuy N.H. and et al. (2005) but different to the ones reported by (Hoang T.T.H. and et al., 2006) and (Binh et al., 2014). Based on ADA 2013 criteria, the percentage of diabetes was 4.42 % in the vegetarian group and 5.47% in the non vegetarian group. However, this difference between the two groups was not significant with  $p > 0.05$ .

The result of this study contrasts to findings of previous studies. Previous studies reported that vegetarians had a lower blood pressure than non-vegetarians, with differences of 2–10 mmHg in systolic or diastolic pressure (Beilin et al., 1988). Appleby et al. (2002) analyzed 57 500 British men and women in EPIC– Oxford cohort. The finding showed that vegans had a lower prevalence of hypertension and lower systolic and diastolic blood pressures than meat eaters. Ashwini (2017) compared metabolic

profile, anthropometric parameters among Indian vegetarians and non-vegetarians. The result showed that levels of lower weight, body mass index, waist and hip circumference of the vegetarians had lower levels than non-vegetarians. Rizzo et al. (2011) found that glucose, blood pressure levels, waist circumference, and BMI were significantly lower ( $P < 0.05$ ) in vegetarians than in non – vegetarians. Kim and Bae (2012) showed there had lower means for body weight, BMI, systolic BP, diastolic BP in vegetarian comparing to non vegetarian. In contrast, in Chinese vegetarians there was a higher level of systolic blood pressure and waist circumference was lower (Hung et al., 2008).

Furthermore, total cholesterol, LDL-cholesterol and HDL-Cholesterol vegetarian in this study was lower than in the non-vegetarian group while triglycerides were significantly higher (all  $p < 0.01$ ). With respect to fasting lipids, we found similar values as reported by Hoang T.T.H. and et al. (2006) and Binh et al. (2014). Similarity, Ashwini (2017) showed that levels of total cholesterol of the vegetarians was lower than in non-vegetarians. However, HDL levels were  $50.57 \pm 9.62$  and  $62.43 \pm 8.07$  respectively for vegetarians and non-vegetarian group and was significantly higher among non-vegetarians ( $p = 0.0001$ ). Chiang et al. (2013) found that Taiwanese vegetarians had lower total cholesterol, lower low density lipoprotein-cholesterol (LDL-C), and lower HDL-C in a multivariate linear regression analysis compared to a non vegetarian group. Eventhough having lower HDL-C level, the vegetarians had significantly lower total cholesterol/HDL-C and LDL-C/HDL-C ratios. Jan et al. (2015) determined the total serum cholesterol and blood pressure in non-vegetarian and vegetarians. Results of the study reported that mean serum cholesterol was significantly higher in non-vegetarians (238.4mg %) than in vegetarians (198.8mg %) while mean serum HDL-cholesterol of non-vegetarians (31.6mg %) was lower than in vegetarians (34.4mg %). Similar results were reported in Chinese vegetarians, where the HDL-cholesterol (HDL-C), fasting plasma glucose (FPG), triglyceride (TG) and diastolic blood pressure (DBP) were lower (Huang et al., 2011). Jung et al. (2013) found that high density lipoprotein cholesterol and total cholesterol were lower in the Buddhist priest group.

### **5.3. Impact of vegetarian diet to metabolic syndrome**

#### ***5.3.1. Prevalence of Metabolic syndrome in the vegetarian and the non-vegetarian group***

This finding demonstrated that the prevalence of metabolic syndrome was not significantly different between vegetarians and non-vegetarians but both groups were characterized by different metabolic syndrome components. The result of this study is

similar findings in other Asian study groups. Shang et al. (2011) found that the vegan diets did not decrease the risk of metabolic syndrome compared with Taiwanese pesco vegetarian, lactovegetarian and non-vegetarian diets. Huang et al. (2011) also revealed that Chinese vegetarians had less chance to have metabolic syndrome.

In contrast meaning, the findings in Western countries are significantly different. Rizzo et al. (2011) reported that the MS was highest in non- vegetarians (39.7%), intermediate in semi-vegetarians (37.6%), and lowest in vegetarians (25.2%) (P for trend < 0.001). Panagiotakos et al. (2004) analyzed the impact of lifestyle habits on the prevalence of the metabolic syndrome. They found that Mediterranean diet was associated with a decreased risk of having the metabolic syndrome. Parm et al. (2015) conducted a study to explain how a vegetarian diet is related to a specific body composition and certain blood biochemical characteristics associated with metabolic syndrome in Estonia. They reported that vegetarianism was associated with a reduced risk of metabolic syndrome. The MS tended to be lowest in vegetarians (25.2%) (P for trend, 0.001) (Rizzo et al., 2011).

### **5.3.2. Impact of risk factors and metabolic syndrome**

In term of risk factors of MS, associations between age and MS and fatness and MS have been reported in many studies. In the present study, these results are confirmed and are in agreement with previous studies in the Vietnamese population. The study of Binh et al. (2014) conducted among the middle-aged population in the Red River Delta region of Vietnam has shown age and BMI as the predicting factor contributing to the increased prevalence of MS with 1.07 times and 1.31 times, respectively. In general, we found the slightly different MS risk among the vegetarian people with age 60 years and older and vegetarian people with overweight (BMI>23) compared to the non-vegetarian group. Bayesian model average (BMA) selected by group: age, sex, study groups, occupation, insurance, BMI, physical activity, smoking, chronic diseases. Regarding BMA model, the best model including high weighted variables in the highest posterior model probability have been used the final analysis.

The similar result found by Kaur (2014) found that increasing age was one of the factors contributing to Metabolic Syndrome. Valachovičová et al. (2006) showed that vegetarians were lower in the age range of 31–40 (n 21), 41–50 (n 38) and 51–64 (n 16) years.

Other studies showed different findings. Jung et al. (2013) conducted the cross-sectional study to compare the prevalence of reflux esophagitis of 148 Buddhist priests.



The finding showed that the prevalence of metabolic syndrome was higher in the Buddhist priest group than general population (30.4 vs 17.6 %). Carnethon et al. (2004) analyzed 575 population with aged 18-30 years to identify risk factors for development of the metabolic syndrome. The result showed that the age-adjusted rate of metabolic syndrome was 10 per 1,000 person-years. BMI and weight gain were risk factors for the metabolic syndrome and regular physical activity might counter this risk.

#### **5.4. Vegetarian diet describing**

Evaluating diet is an important method in explaining the nutrition status. However, this issue is considered as a challenge to any researchers, especially in developing countries like Vietnam where they have to face many limitations on financing, time and study methods as well as the good cooperation from participants.

There are some methods to investigate the nutrition status and describing the diet such as giving questionnaire for participants and recording data for one week; measuring the food intake in household or public kitchen for one week (Ha H.K., 1998). These methods found many difficulties in practical implementation due to long implementing time and lost information, so far the collected information will not be so accurate.

One common and effective method that many researchers applied is food record for 24 hours. This is a simple method in which a 15-20 minutes questionnaire is used for asking the participants about their food intake within 24 hours. If data is collected in large number of participants, it is much more valuable than one - week food record (Ha H.K., 1998).

In our study, we could not investigate the food intake in a large number of participants as well as apply exactly the method of one –week recording for measuring food intake. So we tried to modify the above methods. Therefore, we delivered the food questionnaire for participants to record at home in a week under guidance and follow up by a nutritionist. We have investigated 51 vegetarians and 38 non-vegetarians. Based on data collection, we selected two days for data analysis: one week day (Monday) and one weekend (Saturday).

There were some limitations in our study. Firstly, participants were not familiar to the method at the beginning. It took us a lot of time for explanation, instruction and demonstration how to do food record by oral and materials facilities. Secondly, the vegetarians which were mostly Buddhist Monk and Nun practiced a quite closed

lifestyle. So they were not easy to share personal information including their nutrition habits and practice. The lacking of food measuring devices was the third limitation in our study since we can not pay afford to give the standardized measuring facilities as we planned. However, with the useful help of nutritionists, we tried to overcome the difficulties and get some interesting preliminary findings:

#### **5.4.1. Food habits and practice:**

Based on selecting criteria of strict vegetarians and  $\geq 30$  years old, most of our participants were Buddhist Monks and Nuns which practiced vegetarian diet since they were a child.

Our result showed that 25.49 % of participants practiced vegetarian diet for 5 – 10 years; 41.48 % of the participants practiced vegetarian diet for 10 – 20 years and the percentage of those who were practiced the vegetarian diet for over 20 years was 33.33 %. The length of diet practice was enough to ensure an adequate comparison between vegetarians and non-vegetarians.

82.35 % of total participants practiced vegetarian diet for religious reasons (Buddhist practice requirement). However, there are still 15.69 % of the participants who give health promotion as a main reason and 1.96 % indicated both religious and health promotion reasons. Vegetarian diet for a healthy life is a global trend and it also affect to the perspectives of Vietnamese people. The change of mind on Vietnamese population on nutrition practice is rising in the recent years towards a healthier diet including some days practicing vegetarianism.

For place of eating, which is much related to the food safety and cooking habit, most of the vegetarians in our study chose home (pagodas) for eating (98.04%). In a fact nowadays the Vietnamese society is facing a lot problems related to food poisoning and safety, thus eating at home seems to be a good choice.

33.33 % of vegetarians in our study indicated that they mostly are drinking pure water (88.24%), while 5.88% used mineral water and 5.88 % used soft drink (approximate amount of a glass per meal) when eating. According to some previous researches and recommendations drinking habit during the eating time with an appropriate amount is encouraged for absorbing and digesting food.

Regarding the cooking habit, 90.20 % of vegetarians used Vietnamese rice, only 1.96 % of those used imported rice. Especially, 7.84 % used brown rice which was believed to be good for health. Also, 84.31% of vegetarian used soya oil for cooking;

13.73% of vegetarian used peanut oil and 1.96 % used sesame oil. In vegetarian diet in Asian countries, oil and rice were studied to seek its relation with reported unhealthy vegetarian diet when comparison with Western healthy vegetarian diet.

#### **5.4.2. Food composition:**

In Table 4.27 the distribution of food composition related to energy uptake is shown. Our result shows that average energy intake in the vegetarian group was  $1417 \pm 46.34$  Kcal/ day, significantly lower than in the non-vegetarian group ( $1862 \pm 65.42$ ). In comparison to the national recommendations on nutrition (Ministry of Health, 2000) with the average energy for adult people is about 1900- 2200 kcal/ day for males and 1800- 2100 kcal/ day for females, our result presented much lower values. The central region of Vietnam is considered a poor area in Vietnam in terms of comparison with the North and the South. The people in this region often have lower living conditions than other areas. Also the Buddhist Monks and Nuns usually have a more difficult life than non-religious groups.

Protein, Lipid and Carbohydrate intake of vegetarians in our study was also much lower (2-5 times) compared with the non-vegetarian group and the national recommendations on nutrition (Ministry of Health, 2000).

On table 4.28 the distribution of vitamin and mineral substances (vitamin A, B1, B2, PP and C; Calcium, Phosphate and Ferritin) is shown. All values from the vegetarian group are lower than from the non-vegetarian group and the national recommendation on nutrition.

The lack of energy and nutrients can cause a lot of severe health damages and lower the quality of life. So far, the food composition of vegetarian diet practiced by Hue Vegetarian population showed a severe risk to health. However, as our field observation, the Buddhist Monks and Nuns nutrition status seems to be acceptable. That might be having underlying reason and need to do further studies to find out.

#### **5.5. Limitations of the research**

The study is limited by the fact that in the vegetarian group only nuns and monks were evaluated. The fact that we did not study other vegetarian groups represents a potential bias. Further research should determine whether similar findings can be observed in other vegetarian groups. Another limitation is the small number of males that were included. This relates to the fact that monks were more difficult to convince to participate in the study. Therefore we can only make very limited statements about

vegetarian males. Unfortunately, we could also only gain very limited information about the diet of our participants. This relates to the fact that neither control subjects nor monks or nuns are used to participate in food surveys.

On the other hand, however, it is undoubtful that the findings of our study will pave the way for further research and contribute to a better understanding of how vegetarians differ from non-vegetarians and how Asians differ from other populations in this respect.

## CONCLUSION

Our study was performed in 183 vegetarians and 181 non – vegetarian subjects from central Vietnam showing the following main findings:

- There were considerably more females in both the vegetarian group (84.16%) and the non-vegetarian group (70.72%).

- The mean age of the vegetarian group in our study was  $56.48 \pm 15.41$  years in males and  $58.75 \pm 16.02$  years in females. In the non-vegetarian group, the mean age was  $57.47 \pm 13.85$  years in males and  $51.09 \pm 14.50$  years in females.

- Waist circumference, hip circumference and blood pressure in vegetarian males was significantly lower than in non-vegetarian males ( $p < 0.05$ ), while there was no significant difference in females.

- Total cholesterol, LDL-cholesterol and HDL-Cholesterol was significantly lower in vegetarians than in non-vegetarians while triglycerides were significantly higher (all  $p < 0.01$ ).

- The age-adjusted prevalence of metabolic syndrome in the total population was 19%. The prevalence was slightly lower in vegetarians (15.9%) than in the non-vegetarians (19.9%) without reaching statistical significance.

- The average energy intake in the vegetarian group was  $1417 \pm 46.34$  Kcal/ day, which is significantly lower than in the non-vegetarian group ( $1862 \pm 65.42$ ) and than the national recommendations on nutrition.

- Protein, Lipid and Carbohydrate intake of vegetarians was much lower (2-5 times) compared with the non-vegetarian group and the national recommendations on nutrition

- In the vegetarian group the intake of mineral substances and vitamins was significantly lower than in non-vegetarian group and lower than the national recommendation on nutrition.

## **SUGGESTION**

Based on the research findings described in this report, the following suggestions related to Vietnamese vegetarian diet are made:

1. More studies and publications about the Vietnamese vegetarian diet and its impact on health and non-communicable diseases including the metabolic syndrome should be carried out to promote our understanding on the interaction of diet and non-communicable diseases.
2. Nutritionists should develop guidelines on an appropriate diet for Vietnamese Buddhists, especially the Monks and Nuns living in the pagodas.

## REFERENCES

- Aguilar, M., Bhuket, T., Torres, S., Liu, B. & Wong, R. J. 2015. Prevalence of the metabolic syndrome in the United States, 2003-2012. *JAMA*, 313(19), pp 1973-4.
- Alberti, K., Eckel, R., Grundy, S., Zimmet, P., Cleeman, J. & Donato, K. 2009. Harmonizing the metabolic syndrome. A joint interim statement of the IDF Task Force on Epidemiology and Prevention; NHL and Blood Institute; AHA; WHF; IAS; and IA for the Study of Obesity. *Circulation*, 120(16), pp 1640-1645.
- Albrink, M. J., Meigs, J. W. & Granoff, M. A. 1962. Weight Gain and Serum Triglycerides in Normal Men. *New England Journal of Medicine*, 266(10), pp 484-489.
- Alewaeters, K., Clarys, P., Hebbelinck, M., Deriemaeker, P. & Clarys, J. 2005. Cross-sectional analysis of BMI and some lifestyle variables in Flemish vegetarians compared with non-vegetarians. *Ergonomics*, 48(11-14), pp 1433-1444.
- Alexander, C. M., Landsman, P. B., Teutsch, S. M. & Haffner, S. M. 2003. NCEP-defined metabolic syndrome, diabetes, and prevalence of coronary heart disease among NHANES III participants age 50 years and older. *Diabetes*, 52(5), pp 1210-1214.
- Alexander, D., Ball, M. & Mann, J. 1994. Nutrient intake and haematological status of vegetarians and age-sex matched omnivores. *European journal of clinical nutrition*, 48(8), pp 538-546.
- Anderson, J. W., Smith, B. M. & Washnock, C. S. 1999. Cardiovascular and renal benefits of dry bean and soybean intake. *The American Journal of Clinical Nutrition*, 70(3), pp 464s-474s.
- Appleby, P., Thorogood, M., Mann, J. & Key, T. 1998. Low body mass index in non-meat eaters: the possible roles of animal fat, dietary fibre and alcohol. *International Journal of Obesity & Related Metabolic Disorders*, 22(5), pp.
- Appleby, P. N., Davey, G. K. & Key, T. J. 2002. Hypertension and blood pressure among meat eaters, fish eaters, vegetarians and vegans in EPIC-Oxford. *Public health nutrition*, 5(5), pp 645-654.
- Ashwini 2017. A comparative study of metabolic profile, anthropometric parameters among vegetarians and non-vegetarians- do vegetarian diet have a cardio protective role? 2017, 4(6), pp 6.
- Association, A. D. 2003. Position of the American Dietetic Association and Dietitians of Canada: vegetarian diets. *Journal of the Academy of Nutrition and Dietetics*, 103(6), pp 748.

- Association, A. D. 2013. Standards of medical care in diabetes—2013. *Diabetes care*, 36(Supplement 1), pp S11-S66.
- Avogaro, P., Crepaldi, G., Enzi, G. & Tiengo, A. 1967. Associazione di iperlipemia, diabete mellito e obesita'di medio grado. *Acta Diabetologica*, 4(4), pp 572-590.
- Azizi, F., Salehi, P., Etemadi, A. & Zahedi-Asl, S. 2003. Prevalence of metabolic syndrome in an urban population: Tehran Lipid and Glucose Study. *Diabetes research and clinical practice*, 61(1), pp 29-37.
- Baines, S., Powers, J. & Brown, W. J. 2007. How does the health and well-being of young Australian vegetarian and semi-vegetarian women compare with non-vegetarians? *Public health nutrition*, 10(5), pp 436-442.
- Balkau, B. & Charles, M.-A. 1999. Comment on the provisional report from the WHO consultation. *Diabetic medicine*, 16(5), pp 442-443.
- Barasi, M. & Robinson, F. A study of the use of nutritional supplements by a group of vegetarians in South Wales. AMERICAN JOURNAL OF CLINICAL NUTRITION, 1999. AMER SOC CLINICAL NUTRITION 9650 ROCKVILLE PIKE, SUBSCRIPTIONS, RM L-3300, BETHESDA, MD 20814-3998 USA, 629S-629S.
- Barr, S. I., Janelle, K. C. & Prior, J. C. 1994. Vegetarian vs nonvegetarian diets, dietary restraint, and subclinical ovulatory disturbances: prospective 6-mo study. *The American journal of clinical nutrition*, 60(6), pp 887-894.
- Beezhold, B. L., Johnston, C. S. & Daigle, D. R. 2010. Research Vegetarian diets are associated with healthy mood states: a cross-sectional study in Seventh Day Adventist adults.
- Beilin, L. J., Rouse, I. L., Armstrong, B. K., Margetts, B. M. & Vandongen, R. 1988. Vegetarian diet and blood pressure levels: incidental or causal association? *The American journal of clinical nutrition*, 48(3), pp 806-810.
- Binh, T. Q., Phuong, P. T. & Nhung, B. T. 2014. Metabolic syndrome among a middle-aged population in the Red River Delta region of Vietnam. *BMC endocrine disorders*, 14(1), pp 77.
- Blaha, M. & Elasy, T. A. 2006. Clinical use of the metabolic syndrome: why the confusion? *Clinical Diabetes*, 24(3), pp 125-131.
- Bouchard, C., Després, J.-P. & Mauriège, P. 1993. Genetic and nongenetic determinants of regional fat distribution. *Endocrine reviews*, 14(1), pp 72-93.
- Camus, J. P. 1966. [Gout, diabetes, hyperlipemia: a metabolic trisindrome]. *Revue du rhumatisme et des maladies osteo-articulaires*, 33(1), pp 10-14.
- Carnethon, M. R., Loria, C. M., Hill, J. O., Sidney, S., Savage, P. J. & Liu, K. 2004. Risk factors for the metabolic syndrome. *Diabetes care*, 27(11), pp 2707-2715.



- Circ, J. 2002. New criteria for 'obesity disease' in Japan. *Examination Committee of Criteria for 'Obesity Disease' in Japan, Japan Society for Study of Obesity*, 66(11), pp 987-992.
- Consultation, W. H. O. 1999. Definition, diagnosis and classification of diabetes mellitus and its complications. Part.
- Craig, W. J. & Mangels, A. R. 2009. Position of the American Dietetic Association: vegetarian diets. *Journal of the American Dietetic Association*, 109(7), pp 1266-1282.
- Cross, A. J., Leitzmann, M. F., Gail, M. H., Hollenbeck, A. R., Schatzkin, A. & Sinha, R. 2007. A prospective study of red and processed meat intake in relation to cancer risk. *PLoS medicine*, 4(12), pp e325.
- Chang-Claude, J., Hermann, S., Eilber, U. & Steindorf, K. 2005. Lifestyle determinants and mortality in German vegetarians and health-conscious persons: results of a 21-year follow-up. *Cancer Epidemiology and Prevention Biomarkers*, 14(4), pp 963-968.
- Chen, C., Lin, Y., Lin, T., Lin, C., Chen, B. & Lin, C. 2008. Total cardiovascular risk profile of Taiwanese vegetarians. *European journal of clinical nutrition*, 62(1), pp 138-144.
- Chiang, J.-K., Lin, Y.-L., Chen, C.-L., Ouyang, C.-M., Wu, Y.-T., Chi, Y.-C., Huang, K.-C. & Yang, W.-S. 2013. Reduced risk for metabolic syndrome and insulin resistance associated with ovo-lacto-vegetarian behavior in female Buddhists: a case-control study. *PloS one*, 8(8), pp e71799.
- DeFronzo, R. A. & Ferrannini, E. 1991. Insulin resistance: a multifaceted syndrome responsible for NIDDM, obesity, hypertension, dyslipidemia, and atherosclerotic cardiovascular disease. *Diabetes care*, 14(3), pp 173-194.
- Delavari, A., Forouzanfar, M. H., Alikhani, S., Sharifian, A. & Kelishadi, R. 2009. First nationwide study of the prevalence of the metabolic syndrome and optimal cutoff points of waist circumference in the Middle East. *Diabetes care*, 32(6), pp 1092-1097.
- Duc, P. T. M. 1996. *Arterial blood pressure, Physiology textbook*, Hanoi Medical University: Medical Publishing House.
- Duncan, K. & Bergman, E. Knowledge and attitudes concerning vegetarian diets: differences between dietitians in 3 regions of the United States. *AMERICAN JOURNAL OF CLINICAL NUTRITION*, 1999. AMER SOC CLINICAL NUTRITION 9650 ROCKVILLE PIKE, SUBSCRIPTIONS, RM L-3300, BETHESDA, MD 20814-3998 USA, 634S-634S.
- Einhorn, M., FACP, FACE, Daniel 2003. American College of Endocrinology position statement on the insulin resistance syndrome. *Endocrine Practice*, 9(Supplement 2), pp 5-21.

- Expert Panel on Detection, E. 2001. Executive summary of the Third Report of the National Cholesterol Education Program (NCEP) expert panel on detection, evaluation, and treatment of high blood cholesterol in adults (Adult Treatment Panel III). *Jama*, 285(19), pp 2486.
- Ferrannini, E., Haffner, S., Mitchell, B. & Stern, M. 1991. Hyperinsulinaemia: the key feature of a cardiovascular and metabolic syndrome. *Diabetologia*, 34(6), pp 416-422.
- Ford, E. S. 2005. Prevalence of the metabolic syndrome defined by the International Diabetes Federation among adults in the US. *Diabetes care*, 28(11), pp 2745-2749.
- Fraser, G. & Beeson, W. The dietary habits of vegetarian and nonvegetarian California Adventists. AMERICAN JOURNAL OF CLINICAL NUTRITION, 1999. AMER SOC CLINICAL NUTRITION 9650 ROCKVILLE PIKE, SUBSCRIPTIONS, RM L-3300, BETHESDA, MD 20814-3998 USA, 633S-633S.
- Gacek, M. 2010. Selected lifestyle and health condition indices of adults with varied models of eating. *Roczniki Panstwowego Zakladu Higieny*, 61(1), pp 65-69.
- Graham, I., Atar, D., Borch-Johnsen, K., Boysen, G., Burell, G., Cifkova, R., Dallongeville, J., De Backer, G., Ebrahim, S. & Gjelsvik, B. 2007. † European guidelines on cardiovascular disease prevention in clinical practice: executive summary: Fourth Joint Task Force of the European Society of Cardiology and Other Societies on Cardiovascular Disease Prevention in Clinical Practice (Constituted by representatives of nine societies and by invited experts). *European heart journal*, 28(19), pp 2375-2414.
- Grundy, S. M. 2005. American heart association; national heart, lung, and blood institute. Diagnosis and management of the metabolic syndrome: an American heart association/national heart, lung, and blood institute scientific statement. *Circulation*, 112(2735-2752).
- Grundy, S. M., Brewer, H. B., Cleeman, J. I., Smith, S. C. & Lenfant, C. 2004. Definition of metabolic syndrome. *Circulation*, 109(3), pp 433-438.
- Gu, D., Reynolds, K., Wu, X., Chen, J., Duan, X., Reynolds, R. F., Whelton, P. K., He, J. & Group, I. C. 2005. Prevalence of the metabolic syndrome and overweight among adults in China. *The Lancet*, 365(9468), pp 1398-1405.
- Gupta, A., Gupta, R., Sarna, M., Rastogi, S., Gupta, V. & Kothari, K. 2003. Prevalence of diabetes, impaired fasting glucose and insulin resistance syndrome in an urban Indian population. *Diabetes research and clinical practice*, 61(1), pp 69-76.
- Ha H.K. 2002a. Nutrition needs, Clinical Nutrition, Medical Publishing house, pp 45-64 (In Vietnamese)

- Ha H.K. 2002b. Nutrition, Health and Diseases, Clinical Nutrition, Medical Publishing house, pp 20-43. (In Vietnamese)
- Ha H.K., T. G. 1998. Adequate Nutrition and Health, Medical Publishing house, pp 27-36. (In Vietnamese)
- Haffner, S. M., Valdez, R. A., Hazuda, H. P., Mitchell, B. D., Morales, P. A. & Stern, M. P. 1992. Prospective analysis of the insulin-resistance syndrome (syndrome X). *Diabetes*, 41(6), pp 715-722.
- Hanefeld, M. 1973. Untersuchungen zur Fettleberproblematik unter besonderer Berücksichtigung metabolischer Gesichtspunkte. *Habilitation, Medizinische Akademie, Dresden*.
- Hanefeld, M. a. L., W. 1981. "Das metabolische syndrom (the metabolic syndrome)". *Dt Gesundh- Wesen*. 36(545-551).
- Health, N. I. o. 1998. Clinical guidelines on the identification, evaluation, and treatment of overweight and obesity in adults: the evidence report. *Obes res*, 6(2), pp 51S-209S.
- Himsworth, H. P. 1936. Diabetes mellitus: its differentiation into insulin-sensitive and insulin-insensitive types. *The Lancet*, 227(5864), pp 127-130.
- Hoang T.T.H. and et al. 2006. Study on oral glucose tolerance test in Buddhist in vegan Buddhist Monks and Nuns. *Practical Medicine journal*, 548(100 - 114).
- Hopkins, F. G. 1912. Feeding experiments illustrating the importance of accessory factors in normal dietaries. *The Journal of Physiology*, 44(5-6), pp 425-460.
- Huang, C.-J., Fan, Y.-C., Liu, J.-F. & Tsai, P.-S. 2011. Characteristics and nutrient intake of Taiwanese elderly vegetarians: evidence from a national survey. *British journal of nutrition*, 106(3), pp 451-460.
- Hung, K.-C., Pei, D., Kuo, H.-J., Chen, T.-H., Lin, C.-H., Wu, C.-Z., Hsia, T.-L., Su, C.-C., Hsiao, F.-C. & Lu, C.-H. 2008. The comparison of the metabolic syndrome between Chinese vegetarians and omnivores. *Diabetes & Metabolic Syndrome: Clinical Research & Reviews*, 2(2), pp 99-104.
- I.D.F 2005. IDF Consensus Worldwide Definition of the Metabolic Syndrome. *International Diabetes Federation Brussels*.
- Isomaa, B., Almgren, P., Tuomi, T., Forsén, B., Lahti, K., Nissén, M., Taskinen, M.-R. & Groop, L. 2001. Cardiovascular morbidity and mortality associated with the metabolic syndrome. *Diabetes care*, 24(4), pp 683-689.
- Jan, F., Magray, R. A., Parveen, K., Vaida, N. & Nowseen, N. 2015. Influence of Non-Vegetarian Diet on Serum Cholesterol (Total and Hdl) And Blood Pressure of General Population in District Ganderbal.

- Johnston, P. K. & Sabate, J. 1999. Nutritional implications of vegetarian diets. *Modern nutrition in health and disease*, 10(1641).
- Jung, J. G., Kang, H. W., Hahn, S. J., Kim, J. H., Lee, J. K., Lim, Y. J., Koh, M. S. & Lee, J. H. 2013. Vegetarianism as a protective factor for reflux esophagitis: a retrospective, cross-sectional study between Buddhist priests and general population. *Dig Dis Sci*, 58(8), pp 2244-52.
- Kahn, R., Buse, J., Ferrannini, E. & Stern, M. 2005. The metabolic syndrome: time for a critical appraisal: joint statement from the American Diabetes Association and the European Association for the Study of Diabetes. *Diabetes Care*, 28(9), pp 2289-304.
- Kaplan, N. M. 1989. The deadly quartet: upper-body obesity, glucose intolerance, hypertriglyceridemia, and hypertension. *Archives of internal medicine*, 149(7), pp 1514-1520.
- Kaur, J. 2014. Assessment and screening of the risk factors in metabolic syndrome. *Medical Sciences*, 2(3), pp 140-152.
- Key, T. J., Fraser, G. E., Thorogood, M., Appleby, P. N., Beral, V., Reeves, G., Burr, M. L., Chang-Claude, J., Frentzel-Beyme, R. & Kuzma, J. W. 1999. Mortality in vegetarians and nonvegetarians: detailed findings from a collaborative analysis of 5 prospective studies. *The American journal of clinical nutrition*, 70(3), pp 516s-524s.
- Keys, A., Fidanza, F., Karvonen, M. J., Kimura, N. & Taylor, H. L. 1972. Indices of relative weight and obesity. *Journal of chronic diseases*, 25(6-7), pp 329-343.
- Kim, M.-H. & Bae, Y. J. 2012. Postmenopausal Vegetarians' Low Serum Ferritin Level May Reduce the Risk for Metabolic Syndrome. *Biological Trace Element Research*, 149(1), pp 34-41.
- Kunii, D., Hung, N. T. K., Sakai, T. & Yamamoto, S. 2005. The metabolic syndrome: prevalence and risk factors in the urban population of Ho Chi Minh City. *Diabetes research and clinical practice*, 67(3), pp 243-250.
- Kylin, E. 1923. Studien ueber das Hypertonie-Hyperglyka" mie-Hyperurika" miesyndrom. *Zentralblatt für innere Medizin*, 44(105-127).
- Khan, N. A., McAlister, F. A., Rabkin, S. W., Padwal, R., Feldman, R. D., Campbell, N. R., Leiter, L. A., Lewanczuk, R. Z., Schiffrin, E. L. & Hill, M. D. 2006. The 2006 Canadian Hypertension Education Program recommendations for the management of hypertension: Part II—therapy. *Canadian Journal of Cardiology*, 22(7), pp 583-593.
- Lanou, A. J. & Svenson, B. 2011. Reduced cancer risk in vegetarians: an analysis of recent reports. *Cancer management and research*, 3(1).

- Le D.T., L. T. T., Pham K. 1995. Biological Diagnosis fro some medical diseases. *Hanoi Medical Publishing House*, 20-34.
- Le N.T. 2000. Fully report of basic investigation project of normal biomedical indices in Vietnamese in 1990s. 471 - 473
- Lee, Y.-J. & Krawinkel, M. 2009. Body composition and nutrient intake of Buddhist vegetarians. *Asia Pacific journal of clinical nutrition*, 18(2), pp 265-271.
- Liebig, J. & Gregory, W. 1842. *Animal Chemistry: Or Organic Chemistry in Its Applications to Physiology and Pathology*: Taylor and Walton, Upper Gower Street.
- Luc, K. 2008. *The vegetarian way of Hue people (In Vietnamese)* [Online]. Giac Ngo Newspaper. Available: <https://giacngo.vn/PrintView.aspx?Language=vi&ID=7FD452>.
- Mai, L. H. 1984. Diet for some medical diseases, Medical Publishing House. 6-11.
- Mann, J., Cummings, J., Englyst, H., Key, T., Liu, S., Riccardi, G., Summerbell, C., Uauy, R., Van Dam, R. & Venn, B. 2007. FAO/WHO scientific update on carbohydrates in human nutrition: conclusions. *European journal of clinical nutrition*, 61(S132-S137).
- Mezzano, D., Muñoz, X., Martínez, C., Cuevas, A., Panes, O., Aranda, E., Guasch, V., Strobel, P., Muñoz, B. & Rodríguez, S. 1999. Vegetarians and cardiovascular risk factors: hemostasis, inflammatory markers and plasma homocysteine. *Thrombosis and haemostasis*, 81(6), pp 913-917.
- Milici, N. A short history of the metabolic syndrome definitions. *Proc Rom Acad*, 2010. 13-20.
- Ministry of Health 2004. *Biomedical indices of normal Vietnamese in 1990s- 20th century* Medical Publishing House.
- Ministry of Health, I. o. N. 2000. Table of nutrients from Vietnamese food, Medical Publishing House,. 11-193
- Morgagni, G. B. 1762. *Adversaria anatomica omnia*: Ex Typ. Remondiniana.
- Mozaffarian, D., Benjamin, E. J., Go, A. S., Arnett, D. K., Blaha, M. J., Cushman, M., de Ferranti, S., Despres, J.-P., Fullerton, H. J. & Howard, V. J. 2015. Executive summary: heart disease and stroke statistics-2015 update a report from the American Heart Association. *Circulation*, 131(4), pp 434-441.
- Myong, J.-P., Kim, H.-R., Jung-Choi, K., Baker, D. & Choi, B. 2012. Disparities of metabolic syndrome prevalence by age, gender and occupation among Korean adult workers. *Industrial health*, 50(2), pp 115-122.

- National Research Council 1989. *Recommended dietary allowances*: National Academies Press.
- Nicholson, J. K., Lindon, J. C. & Holmes, E. 1999. 'Metabonomics': understanding the metabolic responses of living systems to pathophysiological stimuli via multivariate statistical analysis of biological NMR spectroscopic data. *Xenobiotica*, 29(11), pp 1181-1189.
- Nutrition Institute. 2011. *Anthropometric measurement technique (In Vietnamese)* [Online]. Available: <http://www.nutrition.org.vn/news/vi/143/126/0/a/ky-thuat-do-nhan-trac.aspx>.
- Nguyen H.T. 2008. Insulin Resistance, Cardiovascular in endocrinal and metabolic disorder. *Hue Publishing House*, 9-58.
- Nguyen Quang Quyen 1978. Anthropometry. *Hanoi Medical Publishing house*.
- Oh, J.-Y., Hong, Y. S., Sung, Y.-A. & Barrett-Connor, E. 2004. Prevalence and factor analysis of metabolic syndrome in an urban Korean population. *Diabetes care*, 27(8), pp 2027-2032.
- Oka, R., Kobayashi, J., Yagi, K., Tani, H., Miyamoto, S., Asano, A., Hagishita, T., Mori, M., Moriuchi, T. & Kobayashi, M. 2008. Reassessment of the cutoff values of waist circumference and visceral fat area for identifying Japanese subjects at risk for the metabolic syndrome. *Diabetes research and clinical practice*, 79(3), pp 474-481.
- Organization, W. H. 2000. Obesity: preventing and managing the global epidemic. Report of a World Health Organization Consultation. Geneva: World Health Organization,
- Palinski-Wade, E. *HOW TO MEASURE YOUR WAIST CIRCUMFERENCE AND WAIST-TO-HIP RATIO* [Online]. Available: <http://www.dummies.com/health/exercise/lose-belly-fat/how-to-measure-your-waist-circumference-and-waist-to-hip-ratio/>.
- Panagiotakos, D. B., Pitsavos, C., Chrysohoou, C., Skoumas, J., Tousoulis, D., Toutouza, M., Toutouzas, P. & Stefanadis, C. 2004. Impact of lifestyle habits on the prevalence of the metabolic syndrome among Greek adults from the ATTICA study. *American heart journal*, 147(1), pp 106-112.
- Parm, Ü., Jürimäe, J., Orav, A., Lätt, E., Sokmann, S., Pedamäe, K. & Tamm, A.-L. 2015. Influence of vegetarian diet to the factors associated with metabolic syndrome. *Journal of Advanced Nutrition and Human Metabolism*, 1(
- Patel, A., Huang, K. C., Janus, E. D., Gill, T., Neal, B., Suriyawongpaisal, P., Wong, E., Woodward, M. & Stolk, R. P. 2006. Is a single definition of the metabolic syndrome appropriate?—A comparative study of the USA and Asia. *Atherosclerosis*, 184(1), pp 225-232.

Paulescu N 1920. *Traité de Physiologie Médicale*, vol 2, Cartea Românească.

Public Health. *Guideline to use Eiyokun software for Vietnamese* [Online]. Available: [http://www.academia.edu/29492459/Hướng\\_dẫn\\_sử\\_dụng\\_phần\\_mềm\\_tính\\_khẩu\\_phần\\_ăn\\_cho\\_người\\_Việt\\_Nam\\_Vietnam\\_Eiyokun](http://www.academia.edu/29492459/Hướng_dẫn_sử_dụng_phần_mềm_tính_khẩu_phần_ăn_cho_người_Việt_Nam_Vietnam_Eiyokun).

Pham V.L. , L. V. A. 2012. *Basic nursing*: Medical Publishing House.

Phan T.S. and et al. 2001. Study of body mass index and blood pressure on nuns population at Hue city, (Vietnamese).

Phuoc D.V and et al. 2010. The guidelines of Vietnam Association of Cardiology.

Rao, D. Role of vegetarian diet in cancers of the esophagus and female breast in India. AMERICAN JOURNAL OF CLINICAL NUTRITION, 1999. AMER SOC CLINICAL NUTRITION 9650 ROCKVILLE PIKE, SUBSCRIPTIONS, RM L-3300, BETHESDA, MD 20814-3998 USA, 624S-624S.

Reaven, G. M. 1988. Role of insulin resistance in human disease. *Diabetes*, 37(12), pp 1595-1607.

Refsum, H. 2001. Folate, vitamin B12 and homocysteine in relation to birth defects and pregnancy outcome. *British Journal of Nutrition*, 85(S2), pp S109-S113.

Report, T. T. H. P. C. s. A. 2017. *POTENTIALS AND PERSPECTIVE* [Online]. Available: <https://www.thuathienhue.gov.vn/en-us/Home/Detail/tid/Potentials-and-perspective/cid/AEBA5AE7-F4B9-4D9B-A507-DE8802BF1D14>.

Rizzo, N. S., Sabaté, J., Jaceldo-Siegl, K. & Fraser, G. E. 2011. Vegetarian dietary patterns are associated with a lower risk of metabolic syndrome. *Diabetes care*, 34(5), pp 1225-1227.

Rousseau, T. 2014. Social health insurance.

Rubner, M. 1883. Vertretungswerthe der organischen Nahrungsstoffe. *Ztschrft der Biologie*, 19(313).

Rubner, M. 1884. *Calorimetrische untersuchungen*: Franz in Komm.

Shang, P., Shu, Z., Wang, Y., Li, N., Du, S., Sun, F., Xia, Y. & Zhan, S. 2011. Veganism does not reduce the risk of the metabolic syndrome in a Taiwanese cohort. *Asia Pac J Clin Nutr*, 20(3), pp 404-10.

Sorrentino Mathew, R. S., Huynh Van Minh., 2001. Alternative risk factor to prevent coronary heart diseases, Hanoi Medical Publishing house. 163-184.

Spencer, E., Appleby, P., Davey, G. & Key, T. 2003. Diet and body mass index in 38 000 EPIC-Oxford meat-eaters, fish-eaters, vegetarians and vegans. *International journal of obesity*, 27(6), pp 728-734.

- Tam Dieu 1999. View of Buddhist vegetarian practice, . *Hoa Sen publishing house*, 4th edition(14-36.
- Tan, C.-E., Ma, S., Wai, D., Chew, S.-K. & Tai, E.-S. 2004. Can we apply the National Cholesterol Education Program Adult Treatment Panel definition of the metabolic syndrome to Asians? *Diabetes care*, 27(5), pp 1182-1186.
- Tanomsup, S., Aekplakorn, W., Sritara, P., Woodward, M., Yamwong, S., Tunlayadechanont, S., Tatsaneeyapan, A., Lim, S. & Rajatanavin, R. 2007. A comparison of components of two definitions of the metabolic syndrome related to cardiovascular disease and all-cause mortality in a cohort study in Thailand. *Diabetes care*, 30(8), pp 2138-2140.
- The Global Diabetes Community Blood Sugar Converter.
- Thuy N.H. and et al. 2005. Study of risk factors in hyperglycemic subjects with pure vegetarian diet. *Practical Medicine Journal*, 507-508(463-472).
- Tran T.V. and et al 1995. Preliminary result of investigation of blood pressure in Hue population in 1994, Hue Central hospital's scientific manual,. 282-288.
- Vague, J. 1947. Sexual differentiation, a factor affecting the forms of obesity. *Presse Med*, 30(339-340).
- Valachovičová, M., Krajčovičová-Kudlačková, M., Blažíček, P. & Babinská, K. 2006. No evidence of insulin resistance in normal weight vegetarians. *European journal of nutrition*, 45(1), pp 52-54.
- Vietnam, N. A. o. t. S. R. o., 2014. Amending and supplementing a number of articles of the Law on Health Insurance, Vietnam, N. A. o. t. S. R. o.
- Voit, C. 1877. *Untersuchung der Kost in einigen öffentlichen Anstalten: für Aerzte und Verwaltungsbeamte*: Oldenbourg.
- World Health Organization 1985. Report of a joint FAO/WHO/UNU expert consultation. *Energy and protein requirements*. World Health Organization, Geneva.
- Zhou, B.-F. 2002. Predictive values of body mass index and waist circumference for risk factors of certain related diseases in Chinese adults--study on optimal cut-off points of body mass index and waist circumference in Chinese adults. *Biomedical and environmental sciences: BES*, 15(1), pp 83-96.
- Zimmet, P. Z. 1993. Hyperinsulinemia—how innocent a bystander? *Diabetes care*, 16(Supplement 3), pp 56-70.



# ACKNOWLEDGEMENT

This Research would not have been possible done without the support, teaching and guidance of all members of Center of International Health, Ludwig – Maximillians University; the Federal Ministry for Economic Cooperation Development; the German Academic Exchange Services and the Excellence center for Exchange Development.

I would like to express my deepest gratitude to my supervisors, Prof. Klaus G. Parhofer, Prof. Cao Ngoc Thanh and Dr. Elisa Waldmann for their patience, support, enthusiasm, and immense knowledge. I greatly benefited from this and could not imagine having better supervisors for my study.

I deeply appreciate the support of all CIH staff member: Ms. Bettina Prüller, Ms. Andrea Kinigadner, Mr. Günter Fröschl, Mr. Karsten Schacht, who always willing to help me at any time during my study.

I would also like to thank the following organizations as a whole for their help and support with data collection, including the Thua Thien Hue Buddhist Church, Hai Duc clinic.

My special thank for the Rector Board of Hue University of Medicine and Pharmacy, The Dean Board of Faculty of Nursing and all staff members, Leaders and staffs of Office of Science-Technology and International relations, integrated planning department, and all other colleagues who supported and encouraged me all the time.

My sincere appreciation is extended to my research team members MNS. Ho Thi Thuy Trang, MNS. Mai Ba Hai, MNS. Ton Nu Minh Duc, MNS. Le Thi Xuan, MNS. Nguyen Thi Minh Thanh, BN. Tran Thi Nguyet, BN. Nguyen Thi Dinh, BN. Dang Thi Thanh Phuc , BN Vo Thi Diem Binh and MPH Tran Binh Thang, MPHMPH.Phan Trung Duc, MT.Pham Thanh Tuong, Ha Van Anh Bao for your invaluable support.

I will always remember CIH PhD 2012 cohort. We did not only take care of each other but also had spent a lot of exciting time during the last five years.

Last but not least, my family, my dear friends, who are always by my side and shared joys and difficulties with me during my study and the whole life. I love all of you.

Thank you very much, everyone!

# Affidavit

Nguyen Thi Anh Phuong

---

Name

---

Street

---

Zip code, town

---

Country

I hereby declare, that the submitted thesis entitled

**Vietnamese vegetarian diet: does it affect the prevalence of metabolic syndrome?**

is the result of my own work. I have only used the sources indicated and have not made unauthorised use of services of a third party. Where the work of others has been quoted or reproduced, the source is always given.

The submitted thesis or parts thereof have not been presented as part of an examination degree to any other university.

I further declare that the electronic version of the submitted thesis is congruent with the printed version both in content and format.

Hue city, April 29, 2017

---

Place, Date

Thi Anh Phuong Nguyen  

---

Signature of PhD Candidate